

MATRIX F82

Operating manual GB



Operating manual for

**Frama Matrix F82
AF/AFS automatic feeder**

Dear Customer,

Thank you for choosing one of the innovative, forward-looking Frama Matrix F82 franking solutions which meets all standards and therefore guarantees long-term protection of your investment. The information below in this operating manual is intended to assist you in installing and operating your Frama Matrix F82. It also shows how you can easily make settings yourself. We have summarized the most important points briefly here for you.

The most important points at a glance:

INSPECTION/AUTOCONNECT.....	17
LOADING POSTAGE (CREDIT).....	16
COST CENTRES/COST CENTRE MANAGEMENT.....	18
INSERTING/CHANGING INK JET CASSETTE.....	27
CHANGING FRANKING DATE (PRINT DATE).....	44
DISPLAY MESSAGES AND TECHNICAL DATA.....	61

You can get quick competent support from our **Help Line** 01992 451125.

The right to make changes in these instructions is reserved. Frama AG also reserves the right to change and/or modify parts of these instructions and/or the product at any time without notice. The postage rates indicated and other information with time-limited validity are provided solely as examples and make no claim to currency.

Safety information and warnings

Thank you for deciding to purchase the innovative Frama Matrix F82 franking system.

The information below in this operating manual is intended to assist you in installing and operating your Frama Matrix F82. It also shows how you can easily make settings yourself.

This franking system meets current safety requirements. Incorrect use can lead to injury and damage. With this in mind, please read this guide before you start using your Frama Matrix F82. This will help you to avoid injury and prevent damage to your franking system. Keep this guide in a safe place and pass it on to the new user should you dispose of the machine.

Symbols used

This operating manual uses the following symbols:



Danger

This symbol indicates dangers and safety hazards which can cause injury when using, operating and servicing the franking system.



Information

This symbol is intended to draw your attention to guidance and instructions you should be aware of which can prevent the risk of damage to the franking system, the items to be posted or the immediate surroundings when handling the franking system.



Tip

Hints and tips of interest for the efficient use of the franking system.

Table of contents

SAFETY INFORMATION AND WARNINGS	4
SYMBOLS USED.....	4
TABLE OF CONTENTS	5
1. SYSTEM PRESENTATION	7
1.1. SAFETY INSTRUCTIONS/NOTES ON USE	7
1.2. USE AS INTENDED/NOTES ON PRINT QUALITY	8
1.3. REQUIREMENTS FOR THE NETWORK ENVIRONMENT/INFORMATION SECURITY	8
1.4. RECYCLING AND DISPOSAL	9
1.5. THE FRAMA MATRIX MACHINE.....	10
1.6. BASIC SCREEN LAYOUT.....	11
2. INSTALLATION	12
2.1. GENERAL NOTES AND SAFETY INFORMATION	12
2.2. CONNECTING THE FEEDER AND FRANKING SYSTEM.....	12
2.3. MAKING CONNECTIONS.....	13
2.4. FILLING THE SEALING SYSTEM (OPTIONAL).....	13
2.5. INSERTING A LABELBOX (FRANKING LABELS).....	13
2.6. CONNECTING TO THE MAINS ELECTRIC SUPPLY.....	14
2.7. FIRST USE.....	15
2.8. FRAMAONLINE2 INSTALLATION	15
2.9. INSTALLING THE INK JET CASSETTE	15
2.10. LOADING POSTAGE CREDIT FROM FRAMAONLINE2	15
3. FRAMAONLINE2	16
3.1. GENERAL NOTES	16
3.2. LOADING POSTAGE CREDIT	16
3.3. INSPECTION/AUTOCONNECT	17
4. OPERATION	18
4.1. SWITCHING ON AND OFF.....	18
4.2. COST CENTRES.....	18
4.3. DETERMINING POSTAGE VALUE	21
4.4. FRANKING	25
4.5. FITTING THE CONSUMABLES.....	27
4.6. AF/AFS AUTOMATIC FEEDER.....	31
5. MAIN MENU.....	39
5.1. OVERVIEW.....	39
5.2. LOGO	39
5.3. PPI.....	42
5.4. DEVICES.....	43
5.5. PRINT DATE	44
5.6. INFO PRINT	45
5.7. PRINTER SETTINGS	47
6. COUNTER READINGS.....	50
7. SETUP (SETTINGS)	51
7.1. SETUP 1 MENU.....	51
7.2. SETUP 2 MENU.....	53

7.3. SETUP 3 MENU.....	54
8. ADMIN MODE.....	55
8.1. LOG IN.....	55
8.2. MAIN MENU.....	55
8.3. COUNTER READINGS.....	56
8.4. SETUP 1.....	56
9. FRAMAONLINE2.....	58
9.1. LOADING POSTAGE CREDIT.....	58
9.2. INSPECTION.....	58
9.3. UNINSTALL.....	58
9.4. CONNECTION.....	58
9.5. LAST REPORT.....	59
9.6. PRINT REPORT.....	59
9.7. SMARTSHOP.....	60
10. TROUBLESHOOTING/ERROR MESSAGES.....	61
10.1. FRAMAONLINE2.....	61
10.2. FRAMA MATRIX F82 SCALES MESSAGES.....	62
10.3. FRAMA MATRIX F82, FRANKING VALUE/CREDIT.....	63
10.4. FRAMA MATRIX F82, PRINTER SETTINGS MESSAGES.....	64
10.5. FRAMA MATRIX F82, FEEDER AND PRINTING.....	65
11. TECHNICAL DATA.....	67
11.1. GENERAL.....	67
11.2. ENVELOPE/ENVELOPE FLAP DIMENSIONS.....	67
11.3. POWER SUPPLY RATING.....	68
11.4. DIMENSIONS AND WEIGHT.....	69
11.5. ACCESSORIES.....	69
11.6. STORAGE AND OPERATING CONDITIONS.....	70
12. EC-DECLARATION OF CONFORMITY.....	71
13. INDEX.....	72

1. System presentation

1.1. Safety instructions/Notes on use



Danger

1. Use this franking system indoors and for franking post and franking labels only. Any other use, modification or change to the franking system is not permissible and may be dangerous. The manufacturer accepts no liability for damage caused by use contrary to the intended use or incorrect operation.
2. Check the franking system for external damage before setting it up. You may be putting your life at risk by using a damaged machine.
3. A damaged connecting lead may only be replaced by a lead of the same type.
4. A current overload protector must always be fitted in buildings in which the franking system is plugged into the mains network.
5. Check the cable and plug before installing the system. Have any damage repaired by a specialist electrician only.
6. Only connect the plug into a mains socket when the franking system housing is closed.
7. Always run the mains cable away from the rear of the franking system and make sure that no risk exists of it being damaged or someone tripping over it.
8. Never pull the plug out of the socket by the mains cable.
9. Never reach into the printing unit. Your fingers could be injured if the franking system is switched on. Be careful if you are wearing long hair, a tie, etc.
10. Do not reach into rotating parts. There is a risk of injury.
11. Keep children away from the franking system.
12. Have your franking system repaired by a service technician from your local Frama sales and service organisation only. Never open the franking system yourself under any circumstances. Repairs carried out incorrectly can represent a significant hazard to the user.

1.1.1. Correct use



Danger

1. Use accessories intended for this system only. The use of accessories that are not approved, or not authorised, can be detrimental to the service life of the franking system. At the same time, a danger to the operator can be created.
2. Always keep your fingers and other parts of the body, ties, necklaces, scarves, open sleeves and similar loose things away from the feed entry area and the rollers. There is a risk of injury on rotating parts.
3. Do not clean the system with flammable fluids. There is a risk of explosion.
4. Disconnect the system from the mains before cleaning it. Clean the system with a damp cloth only. Do not spray any liquids on or into the franking system. There is a risk of electric shock. Lethal hazard.
5. Do not place any liquids, glasses, franking ink, etc. on the franking system.

1.1.2. Installation notes



Information

Your Frama Matrix franking system was manufactured for use in normal conditions. Please remember: Today's furniture is coated with a confusing variety of paints, lacquers and synthetic materials. In view of this, it is quite possible that some of these materials contain constituents which can attack or soften the plastic feet of our equipment. The feet of our equipment, if affected by foreign substances, can stain your furniture. Frama is unable to accept any liability in this respect for obvious reasons. With this in mind, use a non-slip underlay. Avoid exposing directly to sunlight.

1.2. Use as intended/Notes on print quality

The following notes are intended to support you in achieving a sharp, professional print with your Frama Matrix franking system, so as not to jeopardise the delivery of your franked mail. As the user, you are responsible for the legibility of your franking.



Information

1. Your franking machine must be properly registered with the Royal Mail before you use it for the first time. Follow the instructions given by your local Frama Sales and Service organisation when you do this.
2. Each franking mark may be used only once. The Royal Mail (regards repeated use as a punishable offence and a violation of the general terms and conditions of business.
3. Test franking marks or sample franking impressions are not regarded as valid by the Royal Mail and items bearing them may not, therefore, be mailed.
4. The use of fibrous and other unsuitable envelopes can result in the marks blurring or smearing marks and thus to the franking marks being illegible. In view of this, you are urgently advised not to use envelopes of this kind. Do not use very absorbent or fibrous envelopes for this reason. This could invalidate your franking.
5. The use of high gloss envelopes, which could offer insufficient contrast with the franking mark, is not permitted.
6. Do not frank mail items thicker than 10 mm. You risk allowing the printing head to touch the surface of the mail item and thus smearing the franked mark. You should therefore always use Frama Matrix franking labels for thick letters and packets.
7. Please make sure that no sharp objects, such as paper clips, are near the franking zone. Such objects can damage the franking system.
8. Ink jet cassettes must be checked regularly to ensure high-quality printing. After a certain time the printing head is sealed to prevent the individual nozzles from drying. Do not, therefore, switch the franking system off immediately, but wait until the print head is sealed, or use the Log off button.
9. Please run a print head test and clean the print head using the Nozzle Cleaning function (section 5.7.2. Nozzle cleaning on page 47) should you have the impression that there are lines missing from the franked print.

1.3. Requirements for the network environment/information security



Information

1. The franking system is connected to the user's local area network by Ethernet and by the user's internet access correspondingly provided to exchange data with the FramaOnline2 data centre.
2. Frama guarantees that no other data that are not relevant for the franking system from the user's network will be used, transmitted or read.
3. The user must take measures to ensure the integrity and security of the network at all times when operating the franking system on the company network.
4. The PC interface is not active.
5. Consult the quick IP installation file for further information on connecting the franking system. Please click link below to download the guide.
[https://www.frama.co.uk/fileadmin/user_upload/frama_global/documents/Manuals/Franking/Quick IP Installation Guide for LAN.pdf](https://www.frama.co.uk/fileadmin/user_upload/frama_global/documents/Manuals/Franking/Quick_IP_Installation_Guide_for_LAN.pdf)

1.4. Recycling and disposal



The WEEE Directive (Waste Electrical and Electronic Equipment; 2002/96/EC) was drawn up for the protection of human health and the environment to ensure that waste products are disposed of utilising the best available reprocessing, recovery and technical recycling possibilities. Your product has been developed and manufactured using top-quality materials and components which can be recycled and reprocessed.

Do not dispose of this product with household waste.

Please find out about local collection points for electrical and electronic waste products which are marked accordingly.

You can hand over your old product to your specialised dealer/supplier when you purchase a replacement product. The specialised dealer or supplier in Switzerland is obliged to take back used devices by the Swiss Ordinance on the return, taking back and disposal of electrical and electronic appliances.

1.5. The Frama Matrix machine

The figures below show the principal components of the Matrix F82 franking system. Please familiarise yourself with the location of the components.

Fig. Front view (Matrix F82 on PF stand):

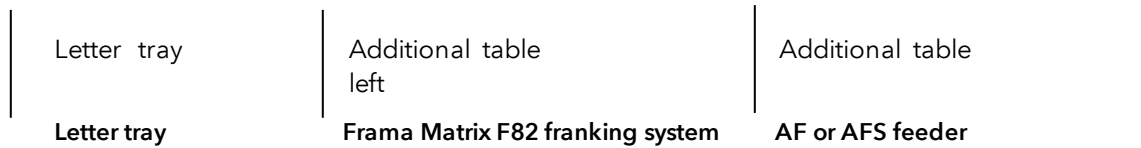
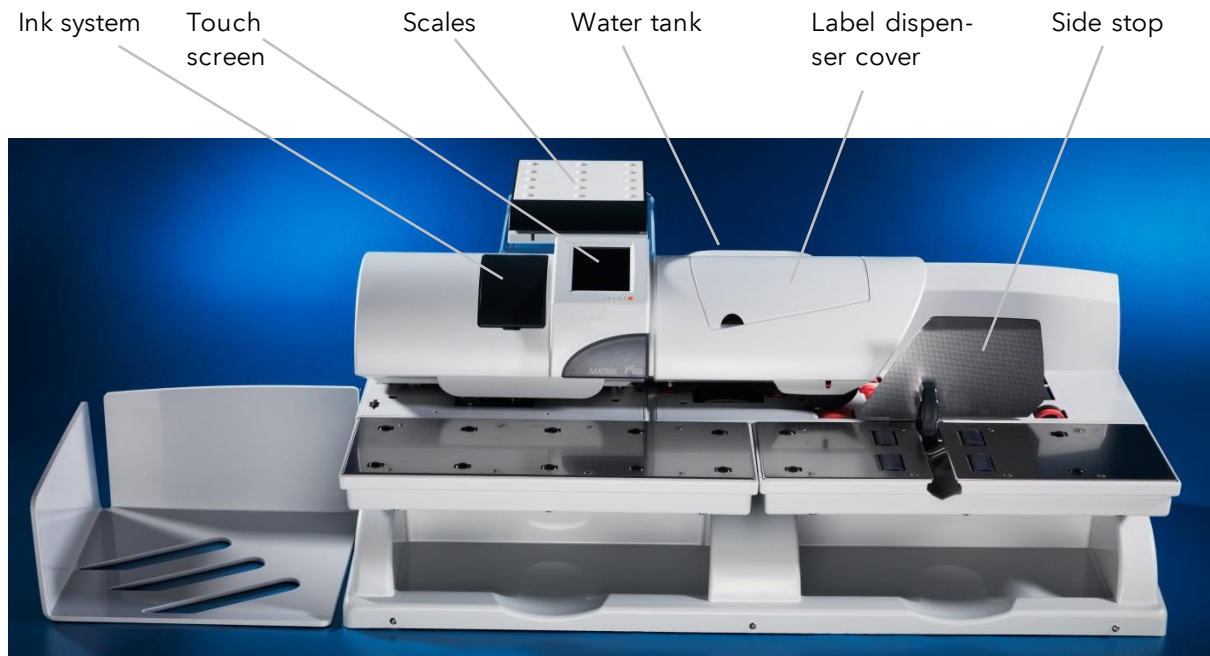



Fig. Rear view (Matrix F82 on PF stand):



1.6. Basic screen layout

The Frama Matrix F82 franking system uses a colour touch screen for operation and navigation through the menus. The colour scheme can be modified in the Setup 3 menu.

 Detailed information concerning the tariff control system screens is available in section 4.3. Determining postage value from page 21.

All the functions that are not available are hidden as a rule. This means that there are differences in the screens between the Admin mode and the Cost Centre mode.

All inputs are made via the touch screen. There are no other keys for operating the machine. The automatic feeder is also controlled via the touch screen.

OneTouch start menu layout

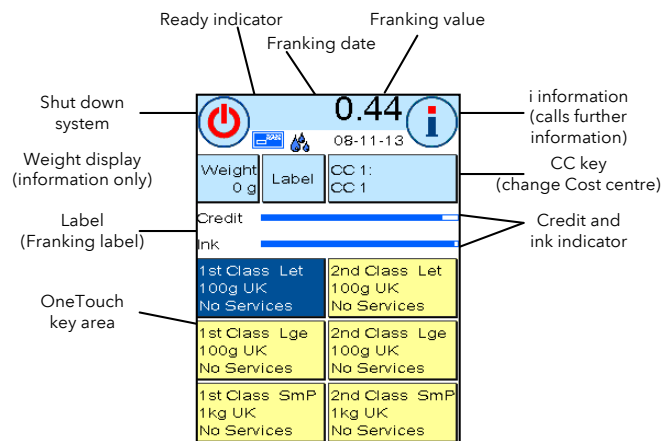

System screen layout (Main Menu)

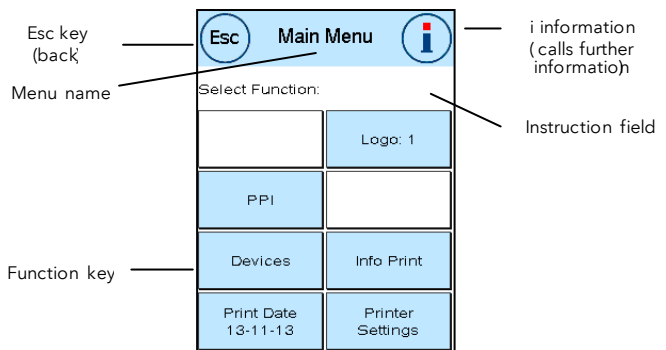

Detail-guided start menu layout

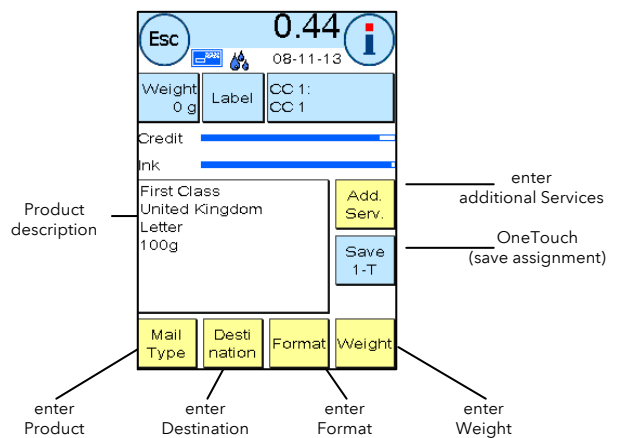

2. Installation

In the normal event, the machine will be installed by a member of our after-sales technical team. **You must also follow the steps in the installation instructions enclosed separately if you wish to install the machine yourself.**

There are four steps to installation:

1. Assembly of the individual components
2. Registering with the FramaOnline2 system
3. Configuring the printer settings
4. Loading postage credit

The information and safety notes below are only a quick reference guide.

2.1. General notes and safety information

Select a position near a mains socket and an Ethernet connection (RJ45) for your Frama Matrix F82. Avoid direct sunlight and severe vibration.

Draughts can affect the accuracy of the scales.

Your Frama Matrix F82 franking system was manufactured for use in normal conditions. Remember: Today's furniture is coated with a confusing variety of paints, lacquers and synthetic materials. In view of this, it is quite possible that some of these materials contain constituents which can attack or soften the plastic feet of our equipment. The feet of our equipment, if affected by foreign substances, can stain your furniture. Frama is unable to accept any liability in this respect for obvious reasons. With this in mind, use a non-slip underlay.

2.2. Connecting the feeder and franking system



Information

Always ensure that you have disconnected the machine from the mains before you make or break the mechanical connection between the feeder and the franking system. Failure to do so may cause the destruction of the franking system. Further information is available on page 36.

2.3. Making connections

The illustration below shows the location of the interfaces on the rear of the Matrix F82's housing (connection panel).

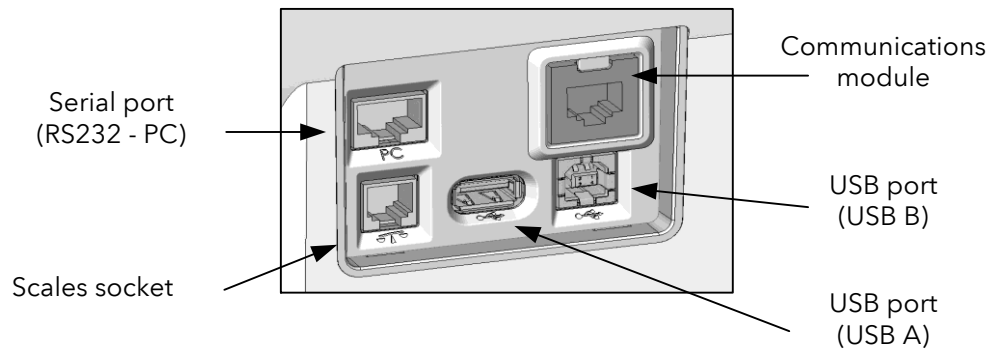

2.3.1. Make communications connection (communications module)

The connection of the relevant cable differs depending on the communications module used.

Ethernet (green): Plug the network cable (RJ45) into this socket. Plug the network cable into your network.

2.3.2. Connecting the scales (optional)

Plug the scales cable into the scales socket.

2.3.3. Connecting additional components (optional)

The options for connecting further components that are optionally available are provided in their instructions. An additional RS232 port and two USB sockets are available.

2.4. Filling the sealing system (optional)

A letter sealing system optionally fitted to your franking system must be supplied with water. Follow the instructions on page 32 to fill the water tank.

2.5. Inserting a Labelbox (franking labels)

Fit the label box carrying the franking labels in accordance with the instructions on page 30.

2.6. Connecting to the mains electric supply



Danger

1. Check the franking system for external damage before setting it up. You may be putting your life at risk by using a damaged machine.
2. Check the cable and plug before installing the system. Have any damage repaired by a specialist electrician only. Do not use the machine until the damage has been repaired.
3. A damaged connecting lead may only be replaced by a lead of the same type.
4. Only connect the plug into a mains socket when the franking machine housing is closed.
5. Always run the mains cable away from the rear of the franking machine and make sure that no risk exists of it being damaged or someone tripping over it.
6. Never pull the plug out of the socket by the mains cable.



Make sure that you have closed all the covers on your Matrix F82 franking system. Make sure the scales platform is not obstructed. Check that the system is switched off (0 must be pressed down).

Pick up the mains cable (power cord). Plug the cable into the mains socket (jack), as shown in the above photo.

Connect the other end of the mains cable to a suitable earthed contact socket.

2.7. First use

When switching the franking system on, you will hear various sounds during the switch-on routines. All the motors and sensors are being checked.



Information: The switch-on routines may take some time. During this time, the Frama Matrix F82 franking system will not accept any input from you.

Information

The franking system must now be installed (registered) with the FramaOnline2 data centre.

2.8. FramaOnline2 installation

Installation on the FramaOnline2 data centre establishes the full functionality of your franking system and is indispensable for the correct operation of the system.



Information: It may be necessary to configure your franking system to ensure that it connects successfully with your network. Follow the instructions on page 58 to make the necessary settings.

Information

A note on installation appears once the system is switched on.

1. Acknowledge the note on installation.
2. Enter the admin PIN. The default value for this PIN is 1234. Press the OK key.
3. Press the "i" key at the top right of the screen.
4. Press the "spanner" key at the top right of the screen.
5. Press the "arrow" key at the top right of the screen.
6. Select FramaOnline2. On the FramaOnline2 screen, select the Installation key. Press the YES key to begin installation.

The franking system contacts FramaOnline2.

Once FramaOnline2 installation is complete, you will be prompted to install the ink jet cassette.

2.9. Installing the ink jet cassette

Follow the instructions on page 27 to install the ink jet cassette correctly.

2.10. Loading postage credit from FramaOnline2

You must load postage credit into the franking system before you can frank mail with your Frama Matrix F82 franking system.

Follow the instructions on page 16. This concludes the installation.

3. FramaOnline2

3.1. General notes

FramaOnline2 will deal with preparing the postage rates, sending user data to the Royal Mail and provides a simple way of loading new postage credit onto your franking system.

Your franking system must set up a connection with the data centre to allow use of FramaOnline2. Refer to section 9.4. Connection, on page 58 for this.



It is only possible to call up postage and communicate with FramaOnline2 in Admin mode. Tip: The Admin mode is password (PIN) protected. Keep your PIN in a safe place. The PIN can only be reset in a chargeable call-out of a service technician to your premises or in the central workshop.

3.2. Loading postage credit

It is only possible to load postage credit in Admin mode. The Admin mode is password-protected. Switch the device on or change to select Cost Centre.

1. In the Select Cost Centre screen, press Admin.
2. Enter your PIN (default: 1234). Then press OK key to access Admin return to the main menu.
3. Press the "i" key.

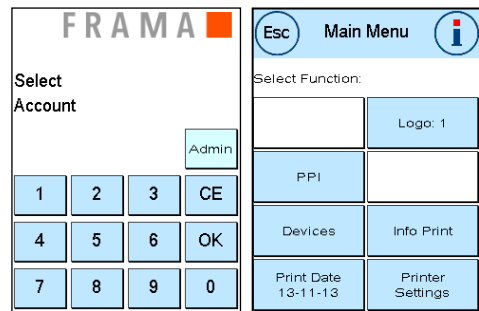

Press the "Spanner" key.

4. Press the "arrow" key.

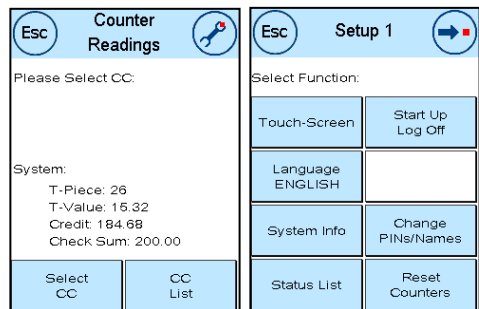

5. Select FramaOnline2.
6. Select Re-set.

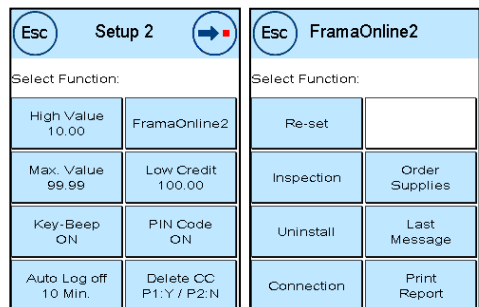

7. Enter the Re-set value desired. Confirm your choice by pressing OK.
8. Your Frama F82 franking system establishes a link with the FramaOnline2 data centre and keeps you informed as to the progress of the connection.

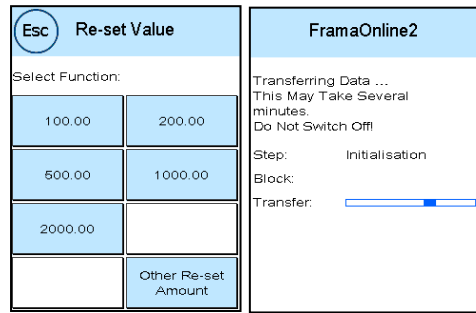

The connection can last several minutes depending on the amount of data to be transferred (postage rates update, etc.).

The transaction data is displayed once the connection is completed.

3.3. Inspection/AutoConnect

Your Matrix F82 franking system has an auto connect function as a convenience. This is used to transmit the counter readings, to check the postage rate tables and to synchronise data with the Royal Mail.

You may see the Auto Connect message while you are changing the cost centre. You can also run this later if you do not wish to make the connection now.

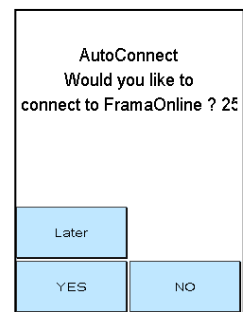

Auto Connect or delivery of the Mailmark™ data is executed in accordance with your agreement with the Royal Mail. If you see the AUTOCONNECT Inspection loading successful message, the connection has been made and you can simply carry on by touching the screen.

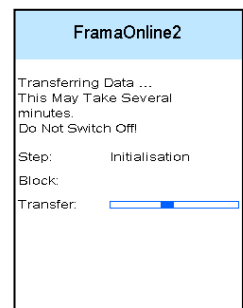

It is important that your franking system is permanently connected through the network for the Inspection/Auto Connect function.

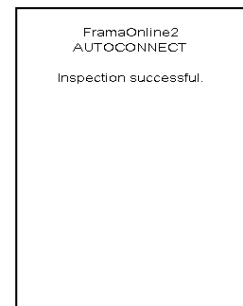

4. Operation

4.1. Switching on and off

Always use the mains switch to switch your franking system on or off after shutting it down. Press “i” on the mains switch to switch the machine on.



You must always press the system shut-down key to shut down the franking system before you switch your Matrix F82 franking system off. This procedure ensures that the print head is properly sealed and cannot dry out.

Information

You can restart your system by pressing Restart system without your first having to operate the mains switch.

The screen is switched off after a specified delay in the Auto Log Off mode (see page 53). Touch the screen to wake the franking system up again.

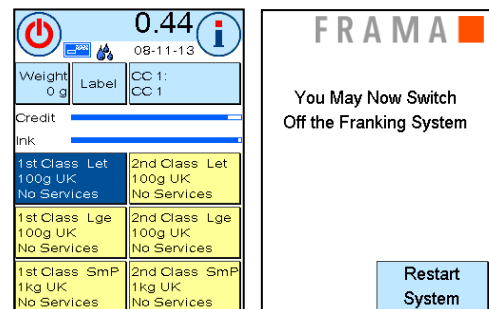

4.2. Cost centres

4.2.1. General comments on cost centres

Your Frama Matrix F82 franking system is equipped with various counters which allow you to monitor postage consumption and the number of mail items franked.

Cost centres are provided to allow you to specifically break down postage consumption. Postage consumption and number of mail items franked can be booked under different periods. These counters are designated as R1-number or R2-number as well as R1-value and R2-value. The R stands for “Resettable”.

Two periods are available to you per cost centre. You can split up the periods individually.

Examples of different periods:

Period 1: Daily report
 Period 2: Weekly report

Period 1: Monthly report
 Period 2: Annual report

Each cost centre can be given its own name. You have up to 16 characters per cost centre. The cost centre active at any time is shown in the top section of the display in the CC key. You may change to another cost centre by pressing this key.

You set up the cost centres in the administration mode.

4.2.2. Displaying the cost centre data

R1-Value/R1-Number: Resettable counters for period 1 R1-Value shows the postage used since the last time this counter was reset. R1-Number shows the number of mail items franked since the last time this counter was reset.

R2-Value/R2-Number: Resettable counters for period 2 R2-Value shows the postage used since the last time this counter was reset. R2-Number shows the number of mail items franked since the last time this counter was reset.

T-Piece/T-Value: Total counter readings for the cost centre. (Number counter and franked value) since the cost centre was set up.

There are also system counters which show the total counters for all cost centres. These counters cannot be reset.

4.2.3. Selecting a cost centre

You must enter a PIN for each cost centre before you can work with your franking system. Unless you have defined new PINs, the PIN for Cost Centre 1 is 1, and for Cost Centre 2 its 2 and so on. This allows the postage costs to be assigned automatically to the appropriate cost centre.

Press 1 and then the OK key to select Cost Centre 1, for instance. The cost centre name will then be displayed and you can now enter the PIN (1). Press OK. The franking screen will be opened and you can frank mail. All franked items will be assigned to this cost centre in respect of value and number.

The selected Cost Centre function can be called up from any start menu again by pressing the CC key. If you are using the Cost Centre Manager, you can call up cost centre selection by pressing the CC key

4.2.4. Cost Centre Manager (CC Manager)

The integrated Cost Centre Manager provides convenient functions for dealing with the cost centres. All setup functions for cost centres, printing and deleting functions are available.

The CC Manager must be enabled in the Setup 3 menu in Admin mode. The CC Manager then pops up automatically before any change of cost centre.

Press the Label key to create a cost centre report on a franking strip. Alternatively, you can press the CC Print out key to create the cost centre report on an envelope.

Press the CC key to access Cost Centre change.

Use the CC setup key to modify the cost centre properties (PIN and name) and to clear the counter readings for the current cost centre.

The After Printing key determines whether the counter readings should be reset after the cost centre report has been printed successfully. Use the Reset After Printing setting for this.

4.2.5. Changing the cost centre PIN

The cost centres are protected by a PIN by default. In the as-delivered state of the franking system, the PIN is the same as the cost centre number. The PIN can have up to 4 digits.

Proceed as follows to change the PIN for the current cost centre:

Press the Change PINs key (in Setup 1 or in the CC Manager under CC Setup).

Enter the old PIN. Press OK to confirm.

Enter the new PIN. Press OK to confirm.

Enter the new PIN again and confirm your input by pressing OK.

You have access to all cost centres in Admin mode (see from page 55).

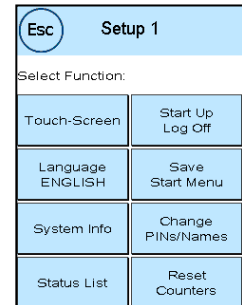

4.2.6. Changing the cost centre name

Your Frama Matrix F82 franking system offers you the option of assigning an individual name to each cost centre. It is supplied by default to the select Cost Centre screen and simplifies your work.

Press the Change PINs key (in Setup 1 or in the CC Manager under CC Setup).

Select Change CC Name and enter the name of the cost centre using the text input screen.

4.2.7. Deleting counter readings of current cost centre

You can delete the counter readings for the current cost centre in the Setup 1 menu or in the CC Manager.

Select the period you wish to delete. Confirm deletion by pressing ENTER. The selection of periods can be defined in the Admin menu.

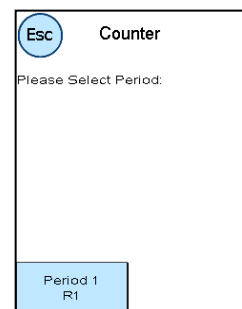

4.3. Determining postage value



Your franking system protects you against unintentionally franking at high postage rates (see Settings section). By default, all franking valued over £10.00 must be approved by touching the postage value displayed (it is initially displayed inverted). This value can be configured in Setup 2 (section 7.2.1. High Value on page 53).

4.3.1. Start menu overview

Four start menus are available to you for efficient franking:

OneTouch

It is not necessary to enter postage values if you use the OneTouch keys. Instead, the mail product concerned is selected by pressing a key. Your Frama Matrix F82 franking system has already been pre-programmed with the most important mail products.

Detail-guided

The details overview of a mail product gives you rapid access to all the properties of the mail product illustrated.

Tariff-guided

Here, you are guided step-by-step through the myriad of postage rates. You can enter the type of mailing, the destination, the weight and the surcharges one after the other here.

Numeric keypad

Postage rates can be entered independently of the mail products using the integrated numeric keypad.

Start menu overview:



OneTouch



Detail-guided



Tariff-guided

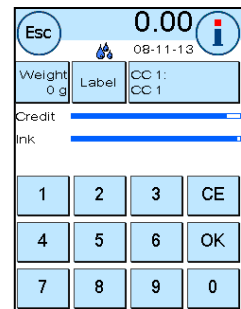

Numeric keypad

4.3.2. OneTouch

Press the OneTouch key for the mail product required. The product is set and you can frank the item as soon as the Ready display appears.

Press a different OneTouch key to change the product. Further OneTouch screens can be called up by touching the postage value.

Each of the OneTouch keys can be reassigned to suit your needs. Press the OneTouch key you wish to change twice, change the properties of the product and press the Save 1-Touch key to save the modified mail product to the OneTouch key.

The OneTouch start menu is configured as a standard start menu when the franking system is delivered. You can change this setting in the Setup 1 menu (see page 51).

Modifying a OneTouch key



Press OneTouch key twice

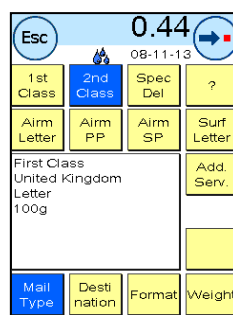

Modify attribute



Press Save 1-T

4.3.3. Detail-guided

Call up the Detail-guided start menu by pressing a OneTouch key twice in the OneTouch menu. You can also set the Detail-guided start menu to be the permanent default start menu in the Setup 1 menu (see page 51).

Each postal product is made up of features predefined by the postal system. These are:

- Mail Type
- Destination
- Format
- Weight
- Additional services (signed for, COD, etc.)

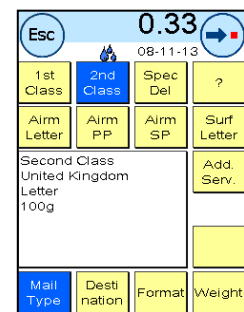

You can modify the properties of the mail product in the Detail-guided start menu at any time. Press the property key (e.g. Destination) and select the new destination.

You can save your changes to the OneTouch key at any time, or return to the OneTouch menu by pressing Esc.

The postage will be recalculated, and you can frank the mail once the Ready prompt appears.

You can also set the Detail-guided start menu to be the permanent default start menu in the Setup 1 menu (see page 51).

4.3.4. Tariff-guided

Call up the Tariff-guided start menu by pressing the Weight field in the OneTouch menu. You will also be taken to this menu when batch weighing is complete.

Then press the Tariff-guided key.

You will be guided through the individual tariff properties one-by-one. The postage will be calculated once the last item for the tariff has been entered. You can begin franking once the Ready prompt appears.



You can also set the Tariff-guided start menu to be the permanent default start menu in the Setup 1 menu (see page 51).

4.3.5. Numeric keypad

Postage rates can be entered independently of the mail products using the integrated numeric keypad.

The numeric keypad is included in the Tariff-guided start menu. Press the franking value.

Enter the postage value required using the keypad. Confirm the value by pressing OK. Assign the amount to a category. You can begin franking once the Ready prompt appears.

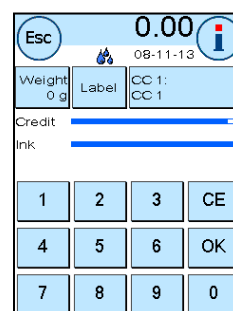

The numeric keypad cannot be defined as the start menu.

4.3.6. Postage scales (optional)

There are a number of ways of determining the precise weight of the mail item using S2, S5 or S30 scales.

4.3.6.1. Checking the weight of a mail item when franking

Caution The weight of a mail item can only be checked if you have set the scales mode to STACK (default setting) in the Setup 3 menu.

Weight information is displayed continuously in the top section of the franking screen (in this case 17g). In view of this, you can have the weight of a mail item conveniently displayed to you without having to interrupt the franking process.

The weight display has no effect on the postage rate calculation.

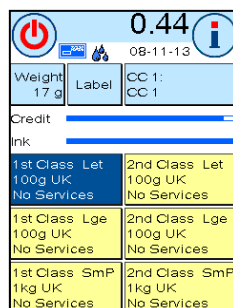

4.3.6.2. Using mail item weight for postal rate calculation

In the detailed overview or the postage rate calculation, press the Weight key and, at any time, by pressing the Scales 17g key, you can retrieve the weight displayed for calculating the postage rate.

Caution:, The procedure described is possible only in the STACK mode.

An analogue balance is displayed in the top section of the screen. This shows you roughly how much of the weight category your mail item is using.

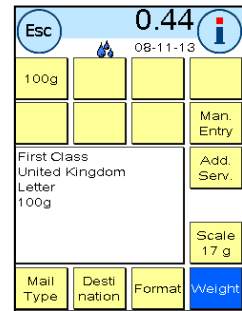

4.3.6.3. STACK/SINGLE weighing mode

Stack weighing mode, with its two variants, is a special feature. Switch the stack weighing mode between Stack and Single in the Main Menu under Devices and in the Setup 3 menu (see page 54).

STACK mode (default)

Place a stack of letters on the scales (it is recommended that they are presorted by format). The total weight of the stack will be shown in the top section of the display. Select a OneTouch key the content of which is nearest to the mail items in the stack.

Take a letter from the stack. The display changes to stack weighing mode. The Weight key provides information as to the weight of the mail item removed from the scales (here: Stack 9g). The postage is calculated on the basis of this weight. Frank the letter.

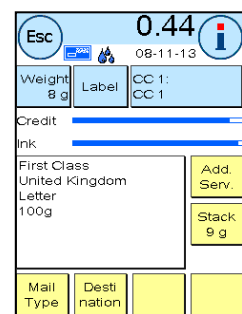

Take the next letter from the stack. The weight of the letter is displayed and the postage calculated accordingly and so on. Once you have removed the last letter from the stack, the stack weighing mode will end after 3 seconds.

You still have access to the type of mailing, format, destination and additional services when you are in the stack weighing mode. A balance shows you how much of the weight category you are using. If it is necessary to adjust further details (e.g. the format) because of the weight, the balance flashes red twice before the postage rate is automatically adjusted.

SINGLE mode

Place a letter on the scales. The weight is determined and automatically transferred.

The display changes to single weighing mode. The Weight key provides information as to the weight of the mail item placed on the scales (here: single 17 g). The postage is calculated on the basis of this weight. Frank the letter.

Place the next letter on the scales. The weight of the letter is displayed and the postage calculated accordingly and so on.

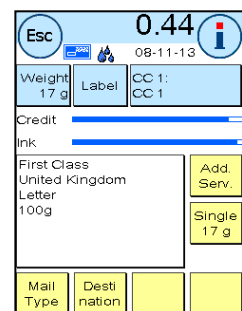

Where necessary, you can adjust individual details for the postage rate. The postage is determined and specified automatically. You can now frank the mail.



The weight is only updated if the weight drops back to 0g; i.e. you have removed the letter from the scales.

Tip

4.4. Franking



Danger

1. Use accessories intended for this system only. The use of accessories that are not approved, or not authorised, can be detrimental to the service life of the franking system. At the same time, a danger to the operator can be created.
2. Always keep your fingers and other parts of the body, ties, necklaces, scarves, open sleeves and similar loose items away from the feed entry area and the feed rollers. There is a risk of injury on rotating parts.
3. Do not clean the system with flammable fluids. There is a risk of explosion.
4. Unplug the system from the mains before cleaning it. Clean the system with a damp cloth only. Do not spray any liquids on or into the franking system. There is a risk of electric shock. Lethal hazard.
5. Do not place any liquids, glasses, franking ink, etc. on the franking system.
6. Do not fill the tanks on the sealing device with any flammable liquids. Risk of explosion.



Information

Use distilled water or hardness degree 1 water if you are using the optional letter sealing unit. Using water of higher hardness grades shortens the letter sealing unit's service life.

It is only possible to frank mail items when the Ready prompt (letter icon) is showing in the display (see page 11).

4.4.1. Adjusting the side stop

You can process your mail items straight from the stack using the AF/AFS automatic feeder. It is not necessary for the mail item thickness to be set. The mail items do not have to be fanned out in advanced.



Danger

Always keep your fingers and other parts of the body, ties, necklaces, scarves, open sleeves and similar loose items away from the feed entry area and the feed rollers. There is a risk of injury on rotating parts.

Further information relating to the AF/AFS automatic feeder may be found from page 31.

You only have to set the mail item width when using the AF/AFS automatic feeder and the side stop provides support when doing so:

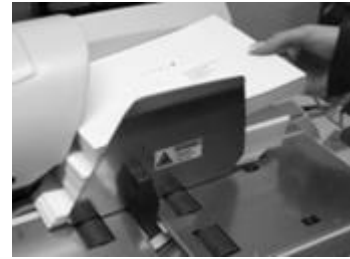

Photo left: Put a small portion of the stack to be franked in the feed and hold the stack firmly.

Photo centre: To move the side stop, grasp it by its black grip; push it up to the stack of letters and release. The stop moves back a little to give the stack some play to single out the mail items perfectly so that they are drawn in smoothly and fault-free. You may now also release the stack of letters.

Photo right: The franking process will start automatically as soon as you release the stack. You can now add further letters to the stack.

4.4.2. Label dispenser (franking labels)

Please use the built-in label dispenser for mail items 10 mm or more thick (e.g. packets).

Press the Label key to do this. Select the number of franking strips required on the numeric keypad and confirm your entry by pressing OK.

Your franking system will print the postage rate specified on the franking strip and eject the strips to the left. Use only original Frama Matrix F82 franking labels.

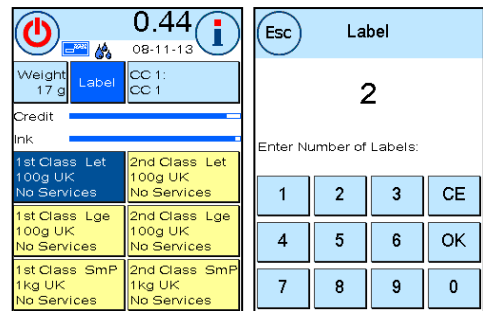

To remove the adhesive label, bend the label at the perforation and peel off the backing paper. The internal tape dispenser is not available in the Stack mode of the AF/AFS feeder.

4.5. Fitting the consumables

4.5.1. Fitting/changing the ink jet cassette

Your Frama Matrix F82 franking system uses a double ink jet cassette to frank your mail items. The ink jet cassette also contains the printing head.

You must therefore handle the ink jet cassette very carefully.



Information

1. Do not frank mail items thicker than 10 mm. You risk allowing the printing head to touch the surface of the mail item and thus smearing the franked mark. You should therefore always use Frama Matrix F82 franking labels for thick letters and packets.
2. Make sure that no sharp objects, such as staples, etc., can damage the sensitive surface of the printing head during franking.
3. Do not use very absorbent or fibrous envelopes which could prevent a cleanly printed mark. This could invalidate your franking.
4. The use of coloured envelopes which offer insufficient contrast with the franking mark is not permitted.
5. After a certain time the printing head is sealed to prevent the individual nozzles from drying. Do not, therefore, switch the franking system off immediately, but wait until the print head is sealed, or use the Shut Down System key.
6. Please run a print head test and clean the print head using the Nozzle Cleaning function should you have the impression that there are lines missing from the franked mark.
7. Do not touch the gold contact surfaces in the ink jet cassette. Grease and perspiration on your skin can leave a film which could result in "messy" print marks.

Please observe the latest installation date (see date printed on ink jet cassette) when you fit your cassette.

Call up the Change Ink Jet Cassette function:

1. Press "i" in one of the start menus.
2. Press the Printer Settings key
3. Press the Change Ink Jet Cassette key

Open the printer cover and remove the ink jet cassette (except for first installation) by squeezing the grip surfaces together and pulling the cassette forwards out of the machine. Dispose of the cassettes in accordance with current regulations.

Printer Settings	
Select Function:	
Print Res. NORMAL	Print Alignm. Label
Nozzle Test	Change Ink-Jet Cassette
Nozzle Cleaning	Print Alignment
Service SHORT	Print Head New Calibration



Unpack the new ink jet cassette and remove the two protective strips from the print head.

On the top of the ink jet cassette you will find two grip surfaces. Press them together between your thumb and forefinger.



Insert the ink jet cassette from above. Follow the contour of the cover as you do this.

Push the new ink jet cassette fully into its guide.

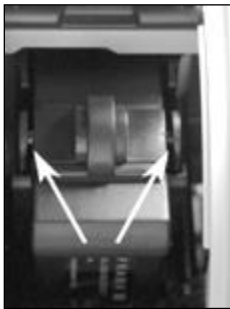

Release the grip surfaces. Push the ink jet cassette back with one finger to make sure that the locking tabs are correctly positioned and that the ink jet cassette is locked into place.



Information

The locking tabs must engage at the side (see photograph above). Check that the ink jet cassette is properly seated before you close the cover again. The cover must close easily without the need for force.

If you have fitted the new cassette properly, you can now press YES on the screen.

The ink jet cassette will now be tested and calibrated. This process might take a few seconds.

If the ink jet cassette being used has already been fitted in your Matrix F82 franking system, you can choose between recalibration and accepting the existing calibration data. Calibrate, are you sure?

After calibration, you will be prompted to print a test franking mark. Take an envelope. We recommend that you use a filled envelope.

Insert the envelope in the AF/AFS automatic feeder. The envelope will be franked with a test mark and ejected to the left.

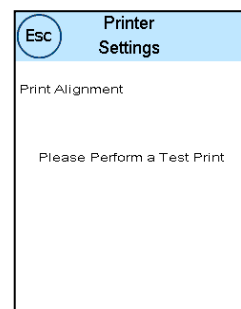

Example of a test print:

Alignment X is shown on the left and Alignment Y on the right. The setting currently valid for each is indicated by an arrow. The arrows should point to where the lines appear straightest.

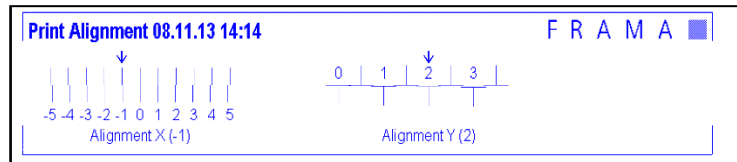

If this is already the case, you only need to confirm the following displays X and Y by pressing the ENTER key. Sometimes, however, it is necessary for you to change the setting to optimise the results. Simply carry out the additional instructions.

This is how you should proceed: Look for the line that appears to be straightest in the Alignment X area to the left of the test mark. Note the number beneath it, e.g. -1.

Use the + and - keys to select the right number in the display and then press ENTER to go to the Y setting.

Again use the + and - keys to select the right number in the display and then press ENTER.

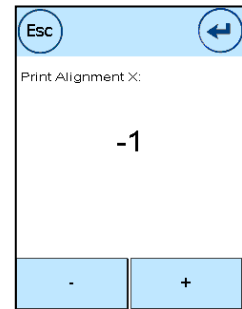

Run a test print again when prompted to check your settings. The arrows will now point exactly to the settings you made, i.e. right where the lines should be straightest.

If you are still not satisfied, you can reset again by answering the prompt with NO. Press YES to save the alignment setting.

If your franking system is fitted with a label dispenser, this is now followed by the same procedure for aligning the printed image on the labels. To do this, follow the instructions on the screen.

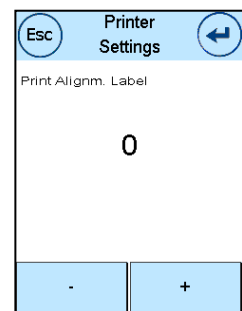

4.5.2. Topping up the franking labels



Open the label compartment on the AF/AFS feeder by lifting up the cover flap. Hook a finger under the cover flap and lift it up. Open the flap completely upwards.



Hold the top end of the hook clamp with the left hand and pull it upwards. Keep the hook clamp in this position. Remove the empty label box, if necessary.



Put the label box into the channel. Push the front open end of the label box under the bottom part of the hook clamp. Then, you can release the hook clamp.



This is how it should look if you have put the label box properly into place. Close the top cover flap again. The strip dispenser is now functional.

4.6. AF/AFS automatic feeder



Danger

1. Use accessories intended for this system only. The use of accessories that are not approved, or not authorised, can be detrimental to the service life of the franking system. At the same time, a danger to the operator can be created.
2. Always keep your fingers and other parts of the body, ties, necklaces, scarves, open sleeves and similar loose items away from the feed entry area and the feed rollers. There is a risk of injury on rotating parts.
3. Never reach into the printing unit. Your fingers could be injured if the franking machine is switched on. Be careful if you are wearing long hair, a tie, etc.
4. Do not reach into the draw-in range. There is a risk of injury.
5. When the additional tables are removed, do not insert your finger into the open recesses in the additional tables on the feeder and on the franking system. There is a risk of injury.
6. Do not clean the system with flammable fluids. There is a risk of explosion.
7. Disconnect the system from the mains before cleaning it. Clean the system with a damp cloth only. Do not spray any liquids on or into the franking system. There is a risk of electric shock. Lethal hazard..
8. Do not place any liquids, glasses, franking ink, etc. on the franking system.
9. Do not fill the tanks on the sealing device with any flammable liquids. Risk of explosion.



Information

Use distilled water or hardness degree 1 water if you are using the optional letter sealing unit. Using water of higher hardness grades shortens the letter sealing unit's service life.

4.6.1. Feeder menu

You can control various functions in the AF/AFS automatic feeder with the Feeder key in the Main Menu.

Press the Devices key in the Main Menu to call up the Feeder menu by pressing on Feeder.

Some functions are only available to you when the optional letter sealing system is fitted.

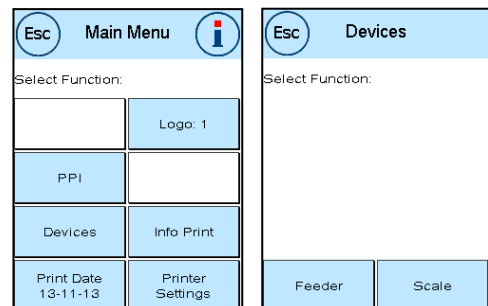

4.6.2. Letter sealer (optional)

The AF/AFS automatic feeder can be equipped with a letter sealing system (optional).

You can select whether the letters are sealed (ON) or not sealed (OFF) by pressing the Letter sealer key. There is no difference in whether envelopes are placed in the AF/AFS feeder open or closed.

The operation of the letter sealer (Letter sealer ON) is shown in the start menus by a stylised symbol next to the letter symbol (🔒).



Tip

You can also press this symbol (🔒) to switch the letter sealer on or off.

Switching the letter sealer on automatically activates the Seal only key. In this event, the mail items will be sealed, but not franked.



Information

1. If envelopes that have already been sealed are used with the Letter sealer ON function, this can cause a paper jam as the feeder tries to seal these envelopes again.
2. Never use washing-up liquid additives or other additives which reduce the water surface tension. Water with a high overall hardness causes leads to shorter service intervals and should thus be avoided.
3. Always remove the letter sealer and the water tank before transporting the franking system. Water could escape and damage the franking system.



Danger

1. Using flammable liquids leads to a high risk of explosion and is therefore prohibited.
2. Transporting the franking system with the letter sealer fitted and filled and the water tank filled can lead to leaks. There is a risk to life from electric shock.

How to fill the letter sealer unit tank with water:



Remove the tank from the back of the AF/AFS feeder by pulling it upwards.



Unscrew the filler cap (it is on the underside of the tank). Fill the tank no more than three-quarters full. Screw on the filler cap again and put the tank back into place.

4.6.2.1. Cleaning letter sealer

From time to time, the letter sealer must be cleaned or have its wearing parts replaced. Use the Clean letter sealer function.

Press the Restart System key after the cleaning operation.

The letter sealer is beneath the water tank. Caution Always use the Clean letter sealer menu item to remove the letter sealer.

If you do not, you may damage the letter sealer mechanism.

How to clean the letter sealer:

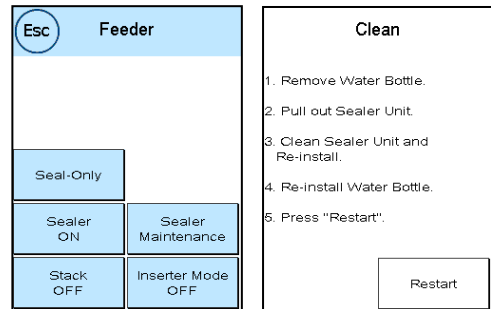

Press the Clean letter sealer key. Do not switch the AF/AFS feeder off.

Remove the water tank.



Locate the letter sealer on the rear of the feeder. Press the two unlocking tabs on the sealer module and pull out of the AF/AFS feeder. **Take care not to spill any water.**



Hold the letter sealer firmly in one hand and remove the moistener.



Clean or replace the moistener. Replace the cleaned or new moistener, refit the letter sealer in the AF, top up the tank with water and replace the tank.

Press the Restart System key.

4.6.3. Stack function

You can define a pre-selection counter with the Stack function. The feeder feeds the pre-selected number of mail items to be franked and then stops.

Press the Stack key in the Feeder menu to switch on the function (Stack ON). Press the key again to switch off the function.

Call the Stack mode using the Stack key in the start menu.

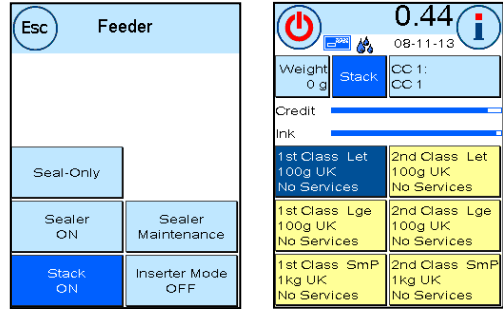

Enter the number of mail items per stack. Start processing the stack by pressing OK or the number entered.



You may switch between the STACK or the SINGLE mode using the „Stack“ or the „Single“ buttons during scale operation .

4.6.4. Inserter Mode

The Inserter mode is a special function of the AF/AFS automatic feeder. This function is required for interaction with an inserter system. Press the Inserter Mode key to enable this function. Press this key again to disable the function.

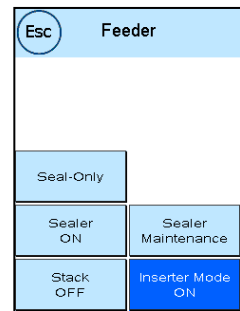

4.6.5 Seal Only/Count Only function

Depending on the letter sealer setting, you can count mail items without franking (Count Only) or seal the items and simultaneously count them (Seal Only). The Seal Only mode is only available when the letter sealer is switched on.

No franking mark is printed. The mail items fed into the machine are counted and sealed, as appropriate.

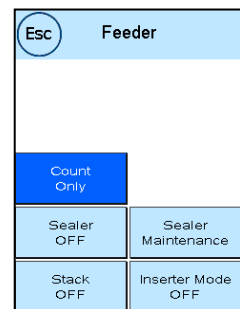

4.6.6. Remedying transport fault in AF/AFS automatic feeder

The transporting area of the automatic feeder can be opened to clear the transport quickly in the event of a fault (paper jams, pieces of paper left lying, etc.).



Caution: Always switch off the franking system before you open the transport area cover. There is a risk of injury on rotating parts.

Danger

How to open the transport area cover:



Slide the lock to the left to the open padlock symbol.



Grip under the transport cover with one hand and pull it upwards until it latches. Remove the jammed envelopes or pieces of paper.



Press the transport cover down with both hands (so that you do not tilt it) until the latch locks and the lock switch returns to its right-hand position.

4.6.7. Separating/connecting the feeder and franking system



Danger

1. First switch the franking system off and then pull out the mains plug before you separate the AF/AFS automatic feeder or the additional tables from the base of the franking machine. There is a risk of electric shock and/or injury.
2. If you wish to use the franking system without the additional tables, the six openings for the additional tables must be closed with covers (available from Frama). It is not permitted to use the machine without these covers.



Information

1. Remove the water tank and the letter sealer before you separate the automatic feeder from the base of the franking machine. Incorrect transport may otherwise lead to water damage.
2. Always separate the franking system base and the feeder if you wish to transport or ship the franking system.
3. Failure to do so may cause the destruction of the franking system.
4. Check that the feeder and the additional tables are fitted properly before using the machine again.

4.6.7.1. Disconnecting the franking system

Observe the safety instructions. If the feeder is fitted with the optional letter sealer, the letter sealer must be removed as described on page 33.

Switch the franking system off. Remove the mains lead and the water tank.

Turn the locking lever for the right-hand additional table anticlockwise to unlock the additional table. Remove the table by folding it upwards. Proceed in the same way as for the left-hand table.



Locking lever on the underside of the additional tables (view from beneath the table).
 Right-hand position (as in photo) = unlocked (table can be removed)
 Left-hand position = locked



Grip the table as shown in the photo to remove the additional tables. You can switch the locking lever over with your fingers so that you can then remove the table.

You can remove the feeder once you have removed the additional tables. Press the release button (see also figures 4 and 5 on the next page) and withdraw the feeder to the right.

4.6.7.2. Connecting the franking system

Line up the Matrix F82 and the AF/AFS automatic feeder opposite one another as shown in Figure 3. The connecting pins on the Matrix F82 must be inserted into the guide holes in the AF/AFS automatic feeder. Familiarise yourself with the connecting pins on the F82 and the guide holes in the AF/AFS feeder:



Figure 1: Matrix F82 with connecting pins



Figure 2: AF/AFS automatic feeder with guide holes

Align the Matrix F82 and the AF/AFS automatic feeder, as shown in Figure 3, and then push the feed guide holes carefully over the connecting pins.



Figure 3: Positioning of Matrix F82 and AF/AFS feeder

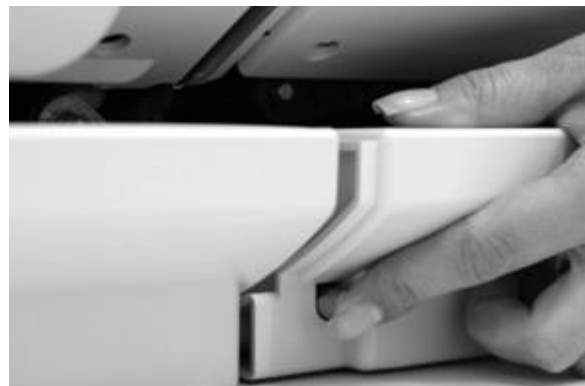

Figure 4: AF/AFS feeder not yet locked.

Press the release button as shown in Figure 4 push the AF/AFS automatic feeder firmly up against the Matrix F82 housing. Let go of the release button. The feeder is now locked in place.

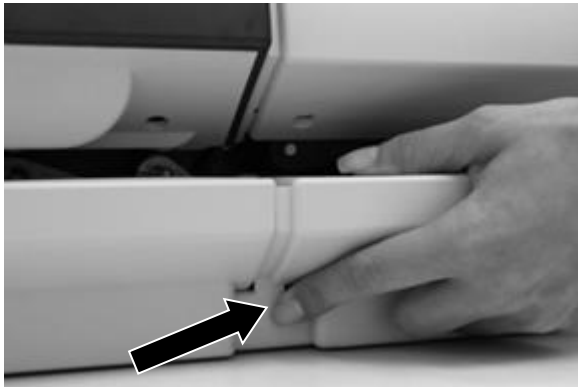

Figure 5: Pressing the release button

You can then fit the left-hand and right-hand additional tables. Make sure that the additional tables are locked correctly. It must be possible to turn the locking lever anticlockwise to the stop. Carefully check that the additional tables are correctly seated before you start using the franking system again.

5. Main Menu

5.1. Overview

The Main Menu is the main control point for all the important system functions. Press the "i" key in one of the start menus to access the Main Menu.

You can select the following functions in the Main Menu.

- PP (see page 42)
- Devices (see page 42)
- Print Date (see page 44)
- Message (see this page)
- Info Print (see page 45)
- Printer Settings (see page 47)

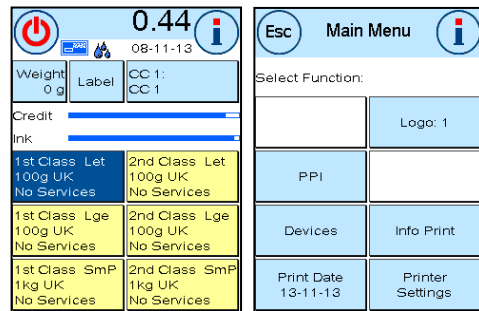

5.2. Logo

Your Frama Matrix F82 franking system already has predefined advertising messages and has been programmed with advertising imprints as you requested. You may also store text messages in the franking system.

Select them as follows:

1. To choose one of the messages, press the "i" key in the Start menu to call up the Main Menu.
2. Press the Logo key. *This could also be labelled Message or Text, depending on the current setting.*
3. Press the Logo key to choose from the stored logos or press the Message key to select from the advertising imprint created from your templates. Press Text to choose one of the texts you have entered.
4. Press the "arrow" key to browse to the next entry.
5. Press the "arrow" key to go to the next message.
6. Press the entry required twice quickly to select.

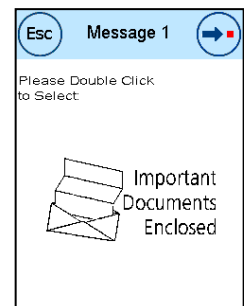
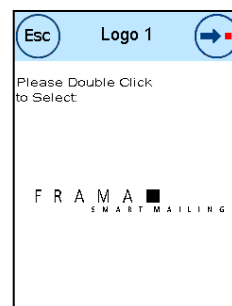
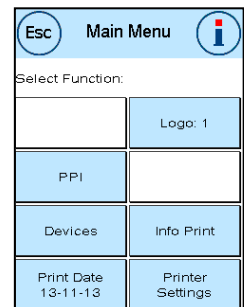

5.2.1. Text blocks

Your Matrix F82 franking system gives you the possibility of producing your own advertising imprint text blocks thus drawing attention to holidays, special campaigns and events with your mail.

A text block can be printed instead of a message or advertising imprint or in addition to a message or an advertising imprint.

5.2.1.1. Entering an advertising imprint text block

Press the "Enter Text" key

Select the text to be written. The text entry screen opens.

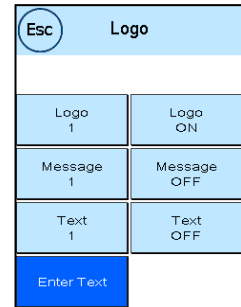

In the text entry screen you can choose upper and lower case, numbers, special characters, punctuation marks and spaces.

Pressing "Enter" key takes you to the next line, whereas you finish text entry with the "Enter" key (symbol at top right). Use the CE key to delete an incorrect entry.

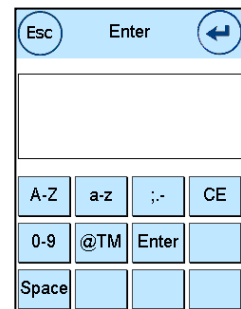

1. Press A-Z for a capital letter. Pressing the Down arrow accesses the other letters. Press the letters required. Press the Left Arrow key to shift to lower case.
2. Enter the small letters as described under point 1.
3. Now press the Enter key to write the next line.
4. To finish the text entry, press the "Enter" key so that the text is saved to the key selected.
5. That's all. You can now choose from your texts in the same way as for messages.

5.2.2. Printing message and text simultaneously

Your Frama Matrix F82 franking system gives you the possibility of printing your text in addition to the selected message. You can set this function by pressing Message & Text.

Esc Logo	
Logo 1	Logo ON
Message 1	Message ON
Text 1	Text ON
Enter Text	



Tip

Caution: If franking labels are used, only restricted utilisation of this function is possible. Your Frama Matrix F82 franking system checks the length of the franking mark and will give you a cue if the permissible total length is exceeded.

Press "Message OFF" key to suppress printing of the message for the franking strip mark. As a result, the franking mark shows only the text message. Using the same procedure, you can cancel printing of the text for the franking strip mark.

This setting is valid only for the process being carried out at the time.

Warning!	
Current Print Settings (Logo and Text) Are Not Suitable For Label Printing.	
	Message OFF
Logo OFF	Text OFF

5.2.3. Switching the message off

You can switch off the message by pressing the Message ON/OFF key if you wish to frank your mail without any message or text.

Press the key again to switch the function back on.

Esc Logo	
Logo 1	Logo OFF
Message 1	Message OFF
Text 1	Text ON
Enter Text	

5.3. PPI

The Matrix F82 allows you also to generate PP marks in addition to the normal franking mark.

Select the PP key in the Main Menu if you wish to be able to generate PP marks.

Make your selection.

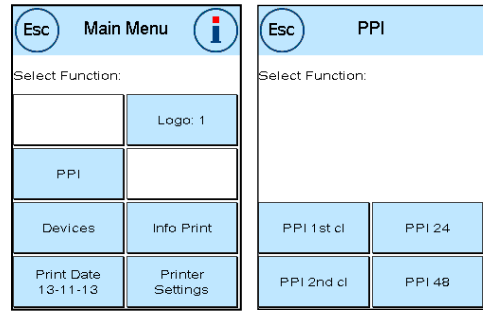

You can now frank your letters. A counter provides information as to the number of mail items franked.

The "Label" key generates franking strips printed with the appropriate PP mark.

You can reset the counter to 0 with the "Reset" Counter key. Use the "Set Counter" key to preset the counter to a specific value.

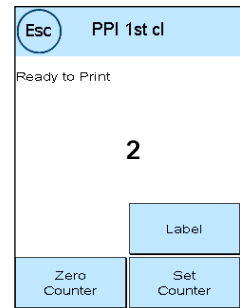

5.4. Devices

The Devices menu item is used to manage connected devices.

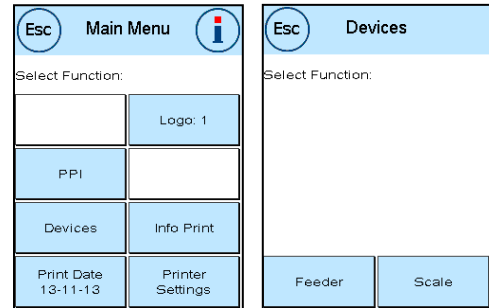

5.4.1. Feeder

The Feeder menu item is described in detail in section 4.6. AF/AFS automatic feeder from page 31.

5.4.2. Scales (optional)

Connecting the S2 or S5 scales automatically extends the functional scope of your Matrix F82, i.e. you can use the scales functions described immediately. By using the electronic scales, you are able to calculate postage rates and weigh your letters, small parcels as well as other mail items accurately. You thus automatically avoid incorrect franking.

Your Matrix F82 franking system has a simple weight display in this menu in addition to the weighing functions in the Start menus already described.

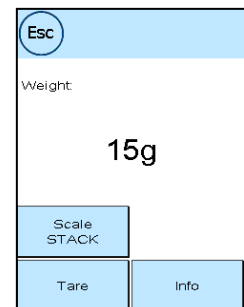

Reset your scales to zero by pressing the "Tare" key.

The "Info" key shows data pertaining to the software used to control the scales of a purely informative nature.

5.4.2.1. STACK/SINGLE scales

This setting determines the mode for the weighing function in conjunction with the scales. The current setting is shown directly in the key.

STACK scales (default): The stack weighing mode is active. Letters removed from the stack are weighed and used in the calculation of postage.

SINGLE scales: The single weighing mode is active. Individual letters placed on the scales are weighed and used in the calculation of postage. The weight information is only updated if the weight on the scales has dropped to 0 g in the interim.

5.5. Print date

Sometimes, it might be necessary for your mail to be franked several days before the delivery date.

To this end, you can set the date printed in the Frama Matrix F82 frank mark up to thirty days ahead.

You can bring forward the date using the + key.

You can push back the date you have previously brought forward using the - key.

The "Reset" key returns you to the current date.

Confirm your choice by pressing the ENTER key. Press ESC to return to the Main Menu without applying the setting.

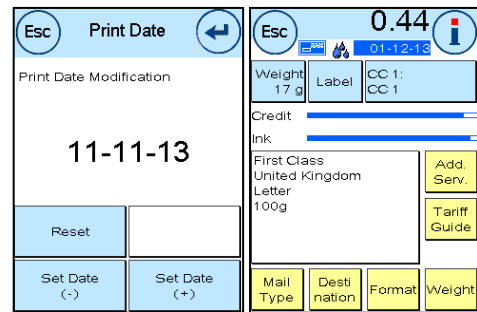

The date brought forward is shown in blue in the franking screen to draw attention to its difference from the current date.



Tip

Please do not forget to reset the system to the current date when you have finished franking with a date brought forward. A change of cost centre automatically resets the date.

5.6. Info Print

You can set various print modes for your Matrix F82 franking system using the Info Prints. The reports are particularly important. These allow condensed information to be printed out. These reports help you by providing overviews when you are programming or, for example, they may be used as receipts after loading postage via the FramaOnline2 data centre.

You can call up further Info Prints by pressing the Next key (right arrow).

5.6.1. Printing out reports

Press the key appropriate to the report you want and feed a C5/6 format envelope into your Frama Matrix F82 franking system to print the report.

You can quit the Info Print menu by pressing ESC.

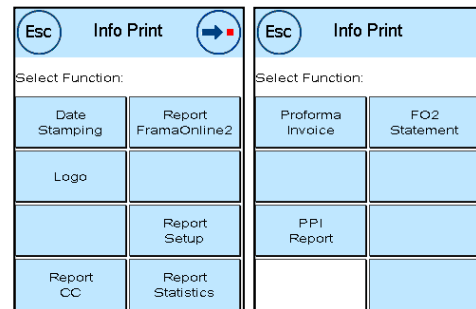

5.6.2. Received stamp

You can convert your Matrix F82 franking system into a received stamping machine. Select the Date Stamping function in the Info Print menu.

This mode changes to a different franking mark. No postage is used.

5.6.3. FramaOnline2 report

The FramaOnline2 report acts as a receipt for the transaction used. You receive information about the sum loaded and the composition of the current credit. The check amount corresponds to the total of all amounts loaded, and it also helps you when you check your transactions.

There are also other FramaOnline2 related reports available when you press the arrow key (**Proforma Invoice** and **FO2 Statement**).

5.6.4. Logo imprint

The Logo print function in the Info Print menu allows you to print the advertising imprint only. All relevant postage information is hidden. This mode does not consume postage.

5.6.5. Setup report (setup settings)

The setup report summarises certain settings of Setup menu 2 (Admin mode) in a clear layout.

5.6.6. CC report

The cost centre report is a clearly laid out report of the data for the current cost centre or for a selected cost centre (Admin mode). You receive the cost centre data for the periods and the overall counter level (not resettable).

5.6.7. Statistics report

The statistics report is used to print out the statistics for the current period. The data collected correspond to the items you have mailed in the time between two connections with the FramaOnline2 data centre. The report extends over several pages (depending on the volume of statistics).

After connecting with the FramaOnline2 data centre, the statistics are automatically deleted and then recompiled using your consumption data.

5.6.8. P.P. report

You may use this report to print out the current counter readings for the PP marks.

5.6.9. Specimen

Use this function to run a postage test print to allow you to assess the print quality, for instance. No postage is used.

The postage test prints may not be used for franking mail items.

5.7. Printer Settings



Information

1. Do not frank mail items thicker than 10 mm. You risk allowing the printing head to touch the surface of the mail item and thus smearing the franked mark. You should therefore always use Frama Matrix F82 franking labels for thick letters and packets.
2. Please make sure that no sharp objects, such as paper clips, are near the franking zone. This can damage the print head.
3. Do not use very absorbent or fibrous envelopes which could prevent a cleanly printed mark. This could invalidate your franking.
4. The use of coloured envelopes which offer insufficient contrast with the franking mark is not permitted.
5. After a certain time the printing head is sealed to prevent the individual nozzles from drying. Do not, therefore, switch the franking system off immediately, but wait until the print head is sealed, or use the Shut system down key.
6. Please run a print head test and clean the print head using the Nozzle Cleaning function should you have the impression that there are lines missing from the franked mark.
7. Always use the functions from the Printer settings menu. Replacing the print head without adjusting the alignment and testing from the Printer Settings menu can lead to inadequate quality of the franking mark.

The Printer Settings menu gives you access to the options and functions required for perfect printing. The functions in the Printer Settings menu are described in sequence below.

5.7.1. Nozzle test

A franking mark test is incorporated in your Frama Matrix franking system.

This test activates each individual nozzle in the printing head. This enables you to easily locate defective nozzles, and also to determine the scope of the cleaning program.

Press the Nozzle Test key and insert an envelope or similar into the system.

A test franking mark is made. Check whether all lines have printed. Run nozzle cleaning if necessary.

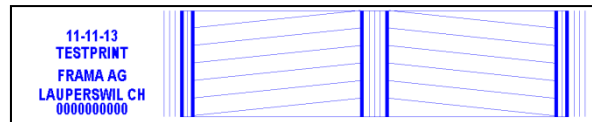

Printer Settings	
Select Function:	
Print Res. NORMAL	Print Alignm. Label
Nozzle Test	Change Ink-Jet Cassette
Nozzle Cleaning	Print Alignment
Service SHORT	Print Head New Calibration

5.7.2. Nozzle cleaning

White lines in the print mark or lines missing from the nozzle test print mean that the print head must be cleaned to restore the print quality.



Information

Blocked nozzles are often the result of the electric supply being disconnected before the nozzles could be properly sealed. Always use the system shut-down function to switch off your franking system reliably.

Two cleaning programmes are available to you for cleaning the nozzles:

Nozzle cleaning: A normal print head cleaning operation is run. The print head and the nozzles are cleaned.

Thorough cleaning of nozzles: Intense rinsing and cleaning of the nozzles and print head.

To call up the required program, press the corresponding button. The cleaning program starts automatically. It is recommended that afterwards you perform the "Nozzle test" function to check that the cleaning was successful.

If you have heavily clogged nozzles which you cannot get clean with the "Clean nozzle" function, instead use a liquid print head cleaner* or alternatively distilled or demineralised water:

1. Remove the ink jet cassette. To do so, use the Change Print Head function (see further below, Chapter 5.7.5. Changing the ink-jet cassette).
2. Moisten a lint-free cloth or a paper-based cleaning cloth with print head cleaner or with water.
3. Wipe the the print head slowly over the moistened cloth. Repeat this procedure until two continuous blue lines become visible.

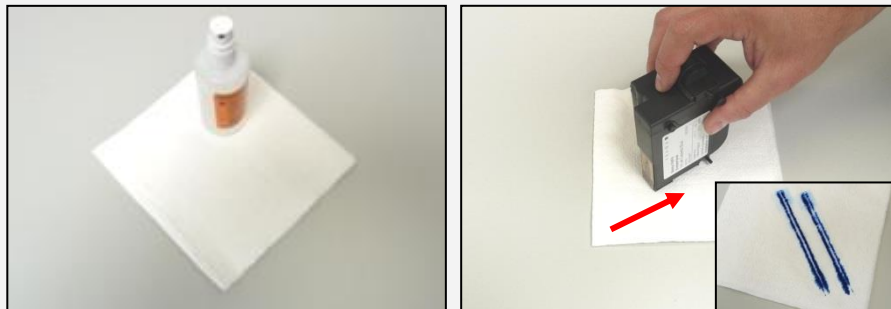

4. Avoid shaking the ink jet cassette; doing so could destroy it.
5. Clean the contacts on the cassette with a cloth. Use only undiluted alcohol or print head cleaning fluid. NEVER use water!

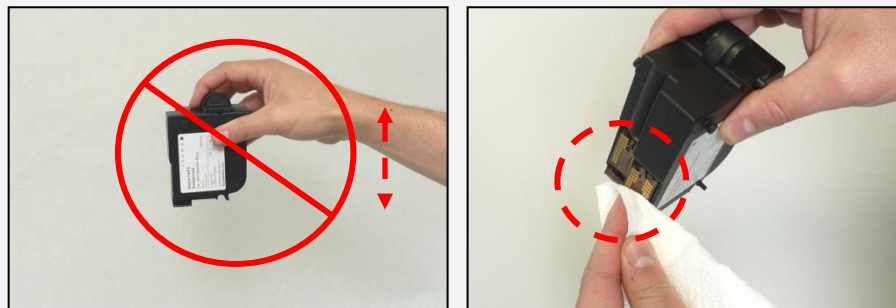

6. Re-insert the ink jet cassette and follow the instructions on Page 30 to adjust it.
7. If the printed impressions are still not satisfactory, please contact our Customer Support Department.

* can be purchased in the FramaShop (www.framashop.co.uk)

5.7.3. Service

The service station will run under the print head after a specified time if you briefly interrupt franking, e.g. because you are inserting new mail items. This means that there is a delay after new mail items are inserted in the machine, as the station must first be parked again.

You can use the Service setting to define the time that the franking system waits before the service station runs under the print head. In this way you are able to adjust the behaviour of the F82 to your way of working.

This setting does not affect the automatic seal after 1 minute's open time.

The following settings are possible:

SHORT = 20 second delay (default)

NORMAL = 40 second delay

LONG = 60 second delay

5.7.4. Label alignment

Use this function to run the adjustment of the print quality for franking labels separately. Normally, alignment will run as part of the configuration following a change of print head.

5.7.5. Changing the ink-jet cassette



Caution: Make sure that the ink jet cassette has been stored at room temperature for at least three hours before you fit it.

Information

Press the Change Ink Jet Cassette key in the Main Menu and confirm by pressing YES.

Open the top cover flap. Remove the ink jet cassette by squeezing together the grip surfaces on the cassette and pulling it out upwards.

Follow the instructions on page 27 to install and align the new ink jet cassette and print head correctly.

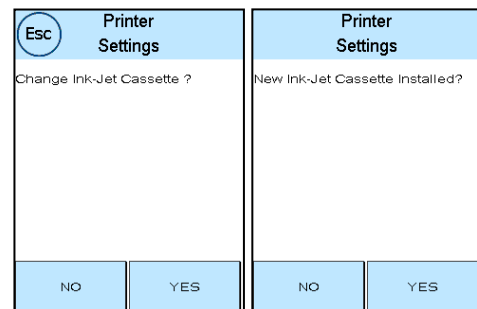

5.7.6. Print alignment

Use this function to run the adjustment of the print quality for franking separately. Normally, alignment is run as part of the configuration following a change of ink jet cassette.

5.7.7. Print head new calibration

Recalibrate the print head (ink jet cassette) if the overall print quality is not satisfactory.

6. Counter Readings

You can access the counter readings from the Main Menu by pressing the "i" key.

The data for the current cost centre is first:

R1-Value/R1-Number: Resettable counters for period 1 The R1-Value shows the postage used since the last time this counter was reset. R1-Number shows the number of mail items franked since the last time this counter was reset.

R2-Value/R2-Number: Resettable counters for period 2 The R2-Value shows the postage used since the last time this counter was reset. R2-Number shows the number of mail items franked since the last time this counter was reset.

T-Number/T-Value: Total counter readings for the cost centre. (Number counter and franked value) since the cost centre was set up.

The system values are listed in addition to the values for the current cost centre:

T-Number/T-Value: Total counter readings for the franking system (number counter and franked value) since the franking system was first used. The total number counter might already show an initial figure because of the tests run before your Matrix F82 franking system was supplied.

Credit: This is the postage still available in your franking system.

Check sum: This is the sum of the credit and T-Value. This amounts to the total credit drawn from FramaOnline2.

Esc	Counter Readings	
Account: 1		
R1-Piece: 26		
R1-Value: 15.32		
R2-Piece: 26		
R2-Value: 15.32		
T-Piece: 26		
T-Value: 15.32		
System:		
T-Piece: 26		
T-Value: 15.32		
Credit: 184.68		
Check Sum: 200.00		

7. Setup (settings)

You can adjust various settings for your Frama Matrix F82 franking system in the Setup menu. Outside Admin mode, you only have the Setup 1 menu available.

Press the "i" key on the Main Menu twice. Then press the Spanner to access the Setup menu.

Calling up the Setup menu

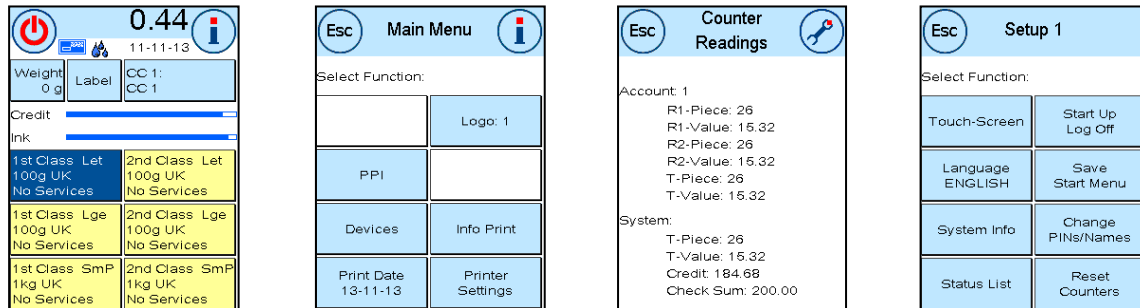

Press "i"

Press "i"

Press Spanner

Use the arrow key to access two further Setup menus in Admin mode. Press ESC to return.

7.1. Setup 1 menu

The description below lists the various functions and settings in the Setup 1 menu from top to bottom. Press the key for the function required and follow the instructions on the screen.

7.1.1. Touch screen

Use this function to adjust the screen contrast to your requirements. Simply press this key and use + or - to adjust to the desired contrast. Apply the modified setting by pressing ENTER.

Press the Colour Scheme key to define the colour scheme.

7.1.2. Language

Your Frama Matrix F82 franking system has a number of languages built in. Switch to the language you require using this function. The current setting is shown in the key. Changing language within a cost centre only changes the operating language; it does not change the language of the tariff module. An inspection loading must be run to also change the language for the tariff module. It is only possible to change the language for the tariff module in Admin mode.

7.1.3. System Info

This key displays a system overview. This information and the information in the status list provides important input for our customer service.

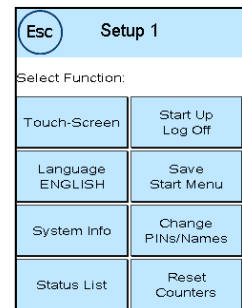

7.1.4. Status List

This key displays a status list. These data and the data in the system information provide important input for our customer service.

7.1.5. Start Up/Log Off

Use this key to restart the system after you have adjusted settings. Pressing Start Up/Log Off takes you straight to cost centre selection.

7.1.6. Save Start Menu

Here you can save a Start Menu as the default. The Start menu saved will automatically be preset after every restart or after a change of cost centre.

7.1.7. Change PINs

This is used for setting up cost centres in Admin mode or for changing PIN and name of the current cost centre. Please read page 18 for more detailed information.

7.1.8. Reset Counters

Please read page 18 for more detailed information.

7.2. Setup 2 menu

Setup 2 menu can be only be accessed in Admin mode (see page 55).

Setup 2	
Select Function:	
High Value 10.00	FramaOnline2
Max. Value 99.99	Low Credit 100.00
Key-Beep ON	PIN Code ON
Auto Log off 10 Min.	Delete CC P1:Y / P2:N

7.2.1. High Value

This setting determines that amount from which, for security reasons, you must confirm the postage value before this amount can be franked. The default setting is £10.00. Enter the new value and confirm your input by pressing ENTER.

7.2.2. Max. Value

Define the maximum permitted franking value with this setting. Press the key, enter the value and acknowledge by pressing OK or ENTER (default = £100.00).

7.2.3. Key Beep

This is used to switch the key beep on and off. Press the key to switch the beep ON or OFF. This setting also affects the signal in batch weighing (default = ON).

7.2.4. Auto Log off

Use this function to define the time until the system closes the current cost centre and calls up the Select Cost Centre screen. Entering 0 minutes switches this function off (default = 10 minutes).

7.2.5. FramaOnline2

The FramaOnline2 functions are explained in detail from page 58.

7.2.6. Low Credit

This setting checks the amount of postage available and warns you in good time that the level is getting too low. Press the Low Credit key to change this setting. Enter the new value. Confirm your change by pressing OK (default = £100.00).

7.2.7. PIN Code

This is used to switch the PIN input on or off. The PIN Code ON setting means that a PIN must be entered in the Select Cost Centre function. The PIN Code OFF setting switches off the request for PIN Code input. The Admin mode is not affected by this.

7.2.8. Delete CC

You can use this to determine which periods are deleted when the cost centre data is cleared (default = period 1 YES, period 2 NO).

7.3. Setup 3 menu

Setup 3 menu can be only be called up in Admin mode.

7.3.1. CC Manager

Specify whether or not you wish to use the extended options in the CC Manager.

ON: The CC Manager is automatically called up when the cost centre is called.

OFF: The CC Manager is disabled.

7.3.2. Logo

Use this setting to define whether all cost centres need to work with the same logo or whether each cost centre may use an individual logo (default = Logo CC).

Logo SYSTEM: All cost centres automatically use the logo defined in Admin mode. The Admin mode has an appropriate function in the Main Menu where you can define the logo.

Logo CC (default): Each cost centre can use an individual logo. The logo is configured accordingly each time a cost centre is called up.

7.3.3. Inserter Mode

The fixed Inserter mode can be specified using this setting (default = Inserter Mode CC).

System Inserter Mode: The inserter mode operates in accordance with the setting in the Main Menu in Admin mode.

CC Inserter Mode: The inserter mode can be selected for each cost centre.

7.3.4. Reset Product on Log Off

This setting defines the behaviour of the start menu when a cost centre is changed (default = OFF).

Setting ON: The current mail product is reset and must be re-entered when the cost centre is changed.

Setting OFF: The current product is retained when the cost centre is changed.

8. Admin mode

Settings made in Admin mode always apply to all cost centres. In Admin mode you also have access to all cost centres and can thus conveniently make settings for these cost centres (counter readings, name and PIN). The additional features demanded by Admin mode are described below.



You can also make settings in each cost centre. However, when you do this not all the Admin mode functions are available to you.

8.1. Log in

Admin mode is called up by pressing the Admin key from the Select Cost Centre screen. This mode is always password-protected, even if you have switched off PIN Code entry for the cost centres.

Press the Admin key to access Admin mode. Enter your PIN. The default PIN is 1234.

Confirm your PIN Code input by pressing OK.

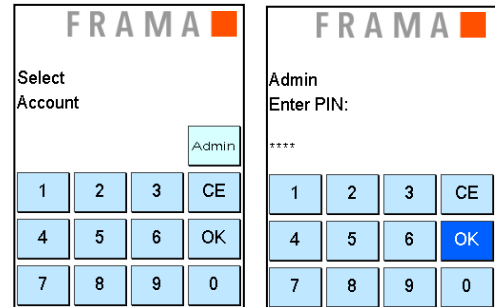

Save the PIN for Admin mode in a safe place. The PIN can only be reset by a service technician at your premises or in the central workshop. This service is chargeable.

8.2. Main Menu



Only those settings that you have defined as SYSTEM in the Setup 3 menu, such as the logo and the settings for the AF/AFS feeder can be adjusted.

You are taken to the Main Menu after logging in. Franking is not possible in Admin mode. The Admin functions in the Main Menu are described below.

8.2.1. Devices

8.2.1.1. Feeder

Specify the inserter mode setting for the system.

The other functions in the Feeder menu do not differ from the descriptions from page 31.

8.2.1.2. Scales

There are no special features in Admin mode.

8.2.2. Logo

Specify the logo setting for the system.

The other functions in the Logo menu do not differ from the descriptions from page 39.

8.2.3. Info Print

In Admin mode, the Cost Centre report has extended selection options for the cost centres to be printed. All other reports and print options correspond to the descriptions given earlier in this operating manual (see section 5.6. Info Print from page 45).

Select CC List from Report CC. Enter the first cost centre to be printed. Confirm the entry by pressing OK. Enter the last cost centre to be printed. Press OK to confirm.

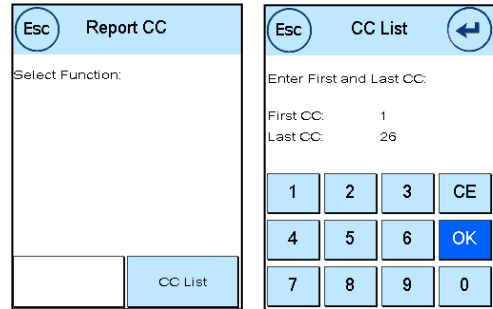

Insert envelopes, report cards, etc., into the feeder. One envelope/report card is printed per cost centre.

8.2.4. Printer Settings

The Printer Settings menu item does not offer any additional functions in the Admin menu.

8.3. Counter Readings

You can display the counter readings of each cost centre shown in Admin mode. You can call up one cost centre or a list of cost centres for this function.

Select CC: Press the key to call up the cost centre selection menu. Select the cost centre.

CC list: Here you can define a range of cost centres for the display of cost centre data. First, enter the number of the cost centre from which the data should be shown. Press OK. Then select the number of the last cost centre to be shown. Continue to the Counter Readings menu using the arrow key. Press ESC to quit the display.

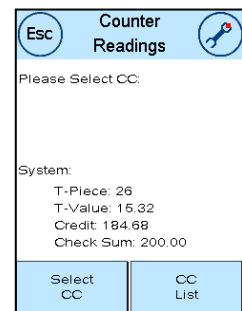

8.4. Setup 1

The Change PINs and Reset Counters functions apply to all cost centres in the Admin mode and therefore offer extended options. The Save Start Menu item is not available in Admin mode.

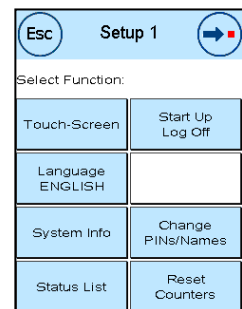

8.4.1. Change PINs

Press the Change PINs key to change the PIN for the Admin mode (Change PIN) or to modify the PINs and names for other cost centres (Select CC).

8.4.2. Reset Counters

Press Reset Counters and select the period to be deleted. Deleting period 2 automatically also deletes period 1.

Select the counters to be reset for a cost centre (Other CC) or a range of cost centres (CC range). The All CCs key deletes the selected period for all cost centres.

Confirm the security prompts to delete the desired cost centres.

8.4.3. Setup 2/Setup 3

The settings for Setup 2 and 3 have already been described in detail from page 53.

9. FramaOnline2

FramaOnline2 is a service provided by Frama which handles postage payment (credit), sends franking data to the Royal Mail, sends logos electronically and provides the latest postage rates for you.

Esc FramaOnline2	
Select Function:	
Re-set	
Inspection	Order Supplies
Uninstall	Last Message
Connection	Print Report

9.1. Loading postage credit

The procedure for loading credit (postage) has already been described in depth on page 16.

9.2. Inspection

You can run inspection loadings with your Frama Matrix F82 franking system. You use them to transmit the counter readings, to check the postage rate tables and to balance data with the Royal Mail.

The inspection loading is a manual version of AutoConnect. Detailed information may be found in section 3.3 Inspection/AutoConnect on page 17.

9.3. Uninstall

This function is used to uninstall your franking system from the FramaOnline2 service. Only use this function when requested to do so by Frama.

9.4. Connection

Pressing the Connection key calls up this menu. A key at the top left shows the communication module currently active. The modules available are listed beneath this.

You should print out the factory settings before you start changing them. Read page 45 for how to do this.

Esc Connection	
Select Function:	
Connection Network	Connection Test
	Network Setup

9.4.1 Network Setup

The instructions for configuring the network connection are supplied separately and are not the subject of this operating manual. In the as-delivered condition, dynamic configuration by DHCP is preset; this provides an automatic connection of your Frama franking system in most cases.

FramaOnline2's address is: fo2.frama.com. Communicate using https via port 443.

**Information**

Current information and instructions for configuring the network connection on your Frama Matrix F82 franking system may be found under Downloads at www.frama.com.

You will also find here a listing of the error messages associated with the network connection and FramaOnline2.

9.5. Last Report

Pressing this key displays the last report transmitted from the FramaOnline2 data centre. Touch the display to return.

9.6. Print Report

Pressing this key will print out the last report transmitted from the FramaOnline2 data centre (see Info Print FramaOnline2). Insert an envelope or similar in the franking system to print out the report.

9.7. SmartShop

SmartShop allows you to order frequently required accessories directly through your franking system.

Call the SmartShop by pressing its key. The subsequent figures may differ depending on your country. The prices are shown for illustration purposes only.

9.7.1. Order accessories/options

Select the item required by pressing the relevant key. Select the quantity of the item using the - and + keys. Press the Order key again to confirm the item selection.

Continue in the same way for further items.

Order		InkJet cassette	
Please Select Articles:			
Ord. Value:	0.00	Select No. of Items:	
Shipping costs:		# 1019138	
InkJet cassette		Items:	1
0		Total Value:	
Labels		-	+
0		Order	

9.7.2. Send order

Press the ENTER key to confirm the full order. Press YES in the Send order menu to send a binding order. The franking system contacts the FramaOnline2 data centre.

A successful transmission is indicated in a summary.

Send Order		FramaOnline2 www.framashop.co.uk	
Pls. refer to our T & C's on www.frama.co.uk			
Ord. Value:			
Shipping costs:			
NO	YES	Thank you very much for your order.	

You may print out a receipt - while the summary is displayed - by feeding an envelope or similar:

Last Message 02.12.13 09:40	Licence: FM2000002	F R A M A
FramaOnline2 www.framashop.co.uk		
Thank you very much for your order.		

You will be supplied and invoiced by your local Frama Sales and Service organisation.

10. Troubleshooting/Error messages

A message will appear in the display of your Frama Matrix F82 franking system if an error has occurred. If you are unable to eliminate the problem yourself, you can obtain support on your Frama hotline or from your local Frama dealer. Keep your customer number and franking system number ready to hand.

The Frama Matrix F82 franking system distinguishes two types of error message:

Information Messages marked with this label indicate a situation that can be remedied by the user (paper jam, etc.) or are of a purely informative nature.

Caution Messages marked with this label indicate a malfunction in the system. Switch the system off and then on again. If the message remains, consult the Frama Service organisation.

Information messages, causes and how to remedy them are described below.

10.1. FramaOnline2

Display message	Cause	Remedy
Welcome. Installation required. See operating manual.	Your franking system has not yet been registered with the FramaOnline2 service.	Run the installation as described in section 2 (page 11).
Connection interrupted.	Your existing connection with the FramaOnline2 data centre was suddenly terminated.	Try again. Perhaps wait a few minutes and then try again. Run an inspection loading.
Franking system locked.	Your system has been locked or unregistered.	
System will soon be locked. Perform Inspection?	The franking system must deliver consumption data to FramaOnline2 for forwarding to the Royal Mail. This message appears five days before the franking system is locked.	Run an inspection loading.
Franking system is locked. Perform inspection?	The franking system cannot continue to frank because a data record required for franking was not updated.	Select Inspection to allow a connection to be made with the FramaOnline2 service. The data record will be updated during inspection.
Language changed. Perform an inspection to load missing text.	You have changed the language in Setup 1. The tariff data must be reloaded to match the new language.	Run an inspection loading.

10.2. Frama Matrix F82 scales messages

Display message	Cause	Remedy
Scales communication error	Frama Matrix F82 franking system not communicating with scales.	Check that the scales cable is plugged in properly. Switch the franking system off and then on again. Please contact us on our hotline if this does not correct the problem.
The scales do not come to rest	The scales platform is not at rest. It is therefore not possible to determine the weight.	The scales should be installed in a vibration-free place. Even the draught from fans, etc., can cause this message.
Overloaded scales	The weight put on the platform exceeds the capacity of the scales.	Please remember: The maximum capacity of the Frama S2 scales is 2kg, 5kg for the Frama S5 scales and 30kg for the S30 scales. Do not use the scales platform as a storage place.
Scale Underload	A weight was on the scales when the franking system was switched on.	Always make sure that the scales platform is clear when the franking system is switched on.

10.3. Frama Matrix F82, franking value/credit

Display message	Cause	Remedy
High value not confirmed.	Security prompt.	Touch the postage value shown inverse in the display. You can change the postage limit that activates the message in the Setup 2 menu in Admin mode.
Maximum franking value exceeded.	Security prompt. The value exceeds the maximum postage value.	You can change the postage limit that activates the message in the Setup 2 menu in Admin mode.
Low Credit	The credit available in your Matrix F82 has dropped below the specified limit of £100.00 (default amount).	Load new postage credit. If necessary, change the warning limit using the relevant function in Admin mode.
Low Credit and ink jet cassette is almost empty.	The credit available in your Matrix F82 has dropped below the specified limit of £100.00 (default amount). At the same time the ink jet cassette is almost empty.	Load new postage credit. If necessary, change the warning limit using the relevant function in Admin mode. Replace the ink jet cassette soon.
No credit.	The remaining value of postage credit is not sufficient for franking.	Load more postage credit onto the system.
AutoConnect Do you wish to connect automatically with FramaOnline2?	Data synchronisation with the Royal Mail.	See section 3.3. Inspection/AutoConnect on page 17.

10.4. Frama Matrix F82, Printer Settings messages

Display message	Cause	Remedy
Perform Calibration of Ink Jet Cassette?	You have inserted an ink jet cassette that has previously been fitted in your Matrix F82.	Select YES if you wish to recalibrate the ink jet cassette or NO if you wish to apply the existing calibration data.
Please insert a suitable cassette.	Incorrect cassette type.	Please use only suitable ink jet cassettes.
Cassette not recognised. Please use only ink jet cassettes suitable for your system.	The cassette you are using is intended for use in a different country.	Insert a new ink jet cassette.
Ink jet cassette is almost empty! Please order a new cassette.	The ink in the cassette is almost finished. (This message appears when 20% or less ink remains).	Please order a new ink jet cassette.
Ink jet cassette is empty. Please insert a new ink jet cassette.		Insert a new ink jet cassette.
The expiry date has passed. Please insert a new ink jet cassette.	The shelf life of the cassette has passed.	Insert a new ink jet cassette. The date is shown on the cassette packaging.
No cassette or defective cassette inserted. Please insert a new cassette and switch the system off and then on again.	Cassette changed without using the appropriate menu or the cassette is defective.	Always use the appropriate menu item in the Printer Settings when changing the cassette.

10.5. Frama Matrix F82, feeder and printing

Display message	Cause	Remedy
Feeder error. Please feed the letters in again.	A letter was fed at an angle and thus not franked.	Feed in the letter again.
Caution: The selected mark is too long for label printing (advertising and text).	The printing mark does not fit onto a franking tape.	Temporarily switch off the text or advertising using the selection function.
Caution The selected mark (logo and text) is too long for the current letter.	The printing mark does not fit onto the letter currently to be franked.	Switch the text or the logo off temporarily in the Main Menu.
Letter in transporter. Please remove and restart the system.	Paper jam.	Remove paper jam (see page 35).
Please refill label dispenser.	There are no more franking labels in the label dispenser.	Please insert a new label box.
Label dispenser paper jam.	Label box not put in place properly.	Please check it for a correct seating.
Paper jam at feed.	You are trying to reseal envelopes that are already sealed. Pieces of paper are in the transport path.	Remove paper jam (see chapter 4.8).
The water tank is missing.		Put the water tank in place.
The water level is low.		Top up the water tank.
The letter is too short.	A letter of this length is not suitable for the automatic feeder (minimum format A6).	Please use only A6 or larger envelopes.
The letter is too short for franking, please use a longer letter. or Feeder error. Adjust side stop.	1st possibility: The report required cannot be printed on the envelope being used. 2nd possibility: The letters to be franked are identified as too short and are thus outside the specification.	1st possibility: Always use envelopes 22cm in length or longer for report printing. 2nd possibility: Set the side stop on the feeder tighter to the envelopes. This avoids excessive side play.
Remove letters from the feeder.	Sensor blocked.	Remove the letters/envelopes from the feeder. You can then reinsert the letters/envelopes.
Printing error because paper not straight/ paper jam. Please always insert the envelopes to be franked straight.	The letter has been drawn in at an angle. This means that it has not been possible to print it properly.	Set the side stop on the feeder tighter to the envelopes. This avoids excessive side play.

Not straight/paper jam
Please re-insert the letters and frank
again.

The letter has been drawn in
at an angle. This means that
it has not been possible to
print it.

The franking image has been buff-
ered. Insert the last (unfranked) letter
again. The letter will now be franked.

Not straight/paper jam
Reprinting required.
Please confirm.

The letter has been drawn in
at an angle. This means that
it has not been possible to
print it.

The franking image has been buff-
ered. Confirm the message and insert
the last (unfranked) letter again. The
letter will now be franked.

No display message, but the letter was
not franked and the franking system
beeped three times.

The letter could not be iden-
tified.

Put the letter in place again.

11. Technical data

11.1. General

Matrix F82: Speed:	8500 letters/hour
Maximum letter thickness:	10 mm
Display:	graphical, touch-sensitive screen
Default process:	FramaOnline2
Number of fixed stored advertising messages:	3
Number of customer-specific advertising messages:	up to 12
Number of freely definable texts:	3
Dimensions of advertising message:	52 x 25 mm

11.2. Envelope/envelope flap dimensions

Minimum format (length x width)	148 mm x 95 mm
Maximum format (length x width)	353 mm x 353 mm

Minimum opacity of envelopes/cards

Minimum thickness of cards	0.1 mm
Minimum thickness of envelopes	0.1 mm

Maximum envelope thickness: 10mm

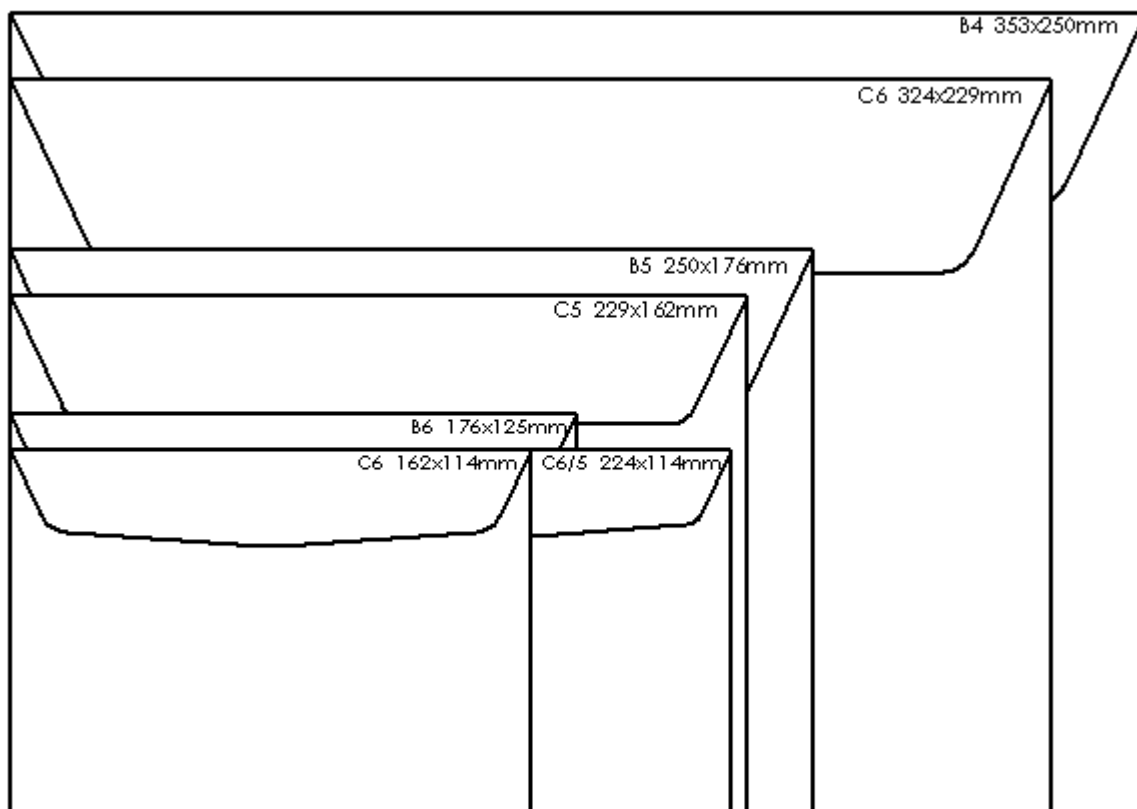

Figure: Formats and dimensions

Envelope flap specifications/maximum and minimum envelope dimensions:

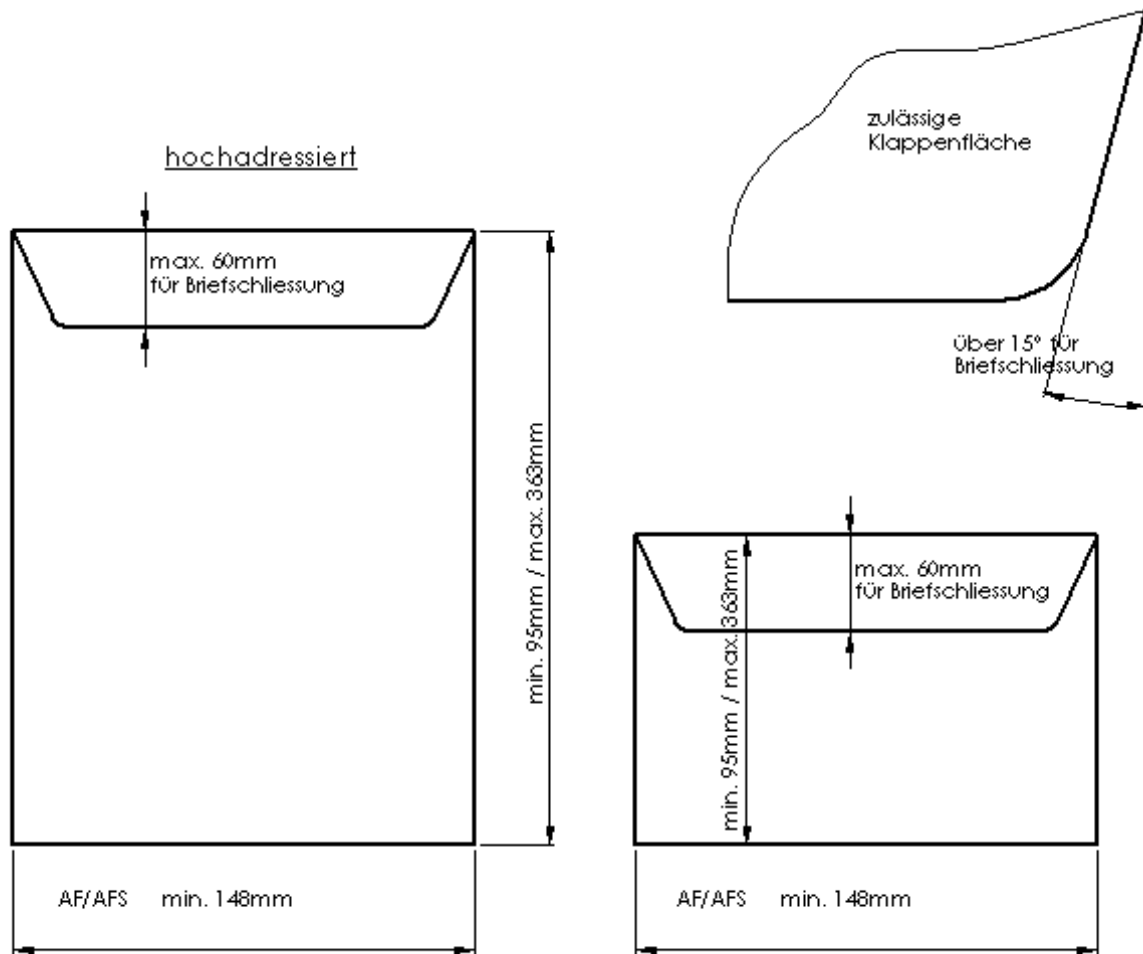

Figure: Envelope flap specification for letter sealer/maximum and minimum envelope specifications

11.3. Power supply rating

Matrix F82:
AF/AFS automatic feeder:

24V DC, 1.5 A (from AF/AFS)
90 - 264 V AC, 47-63 Hz, 1.2 A

11.4. Dimensions and weight

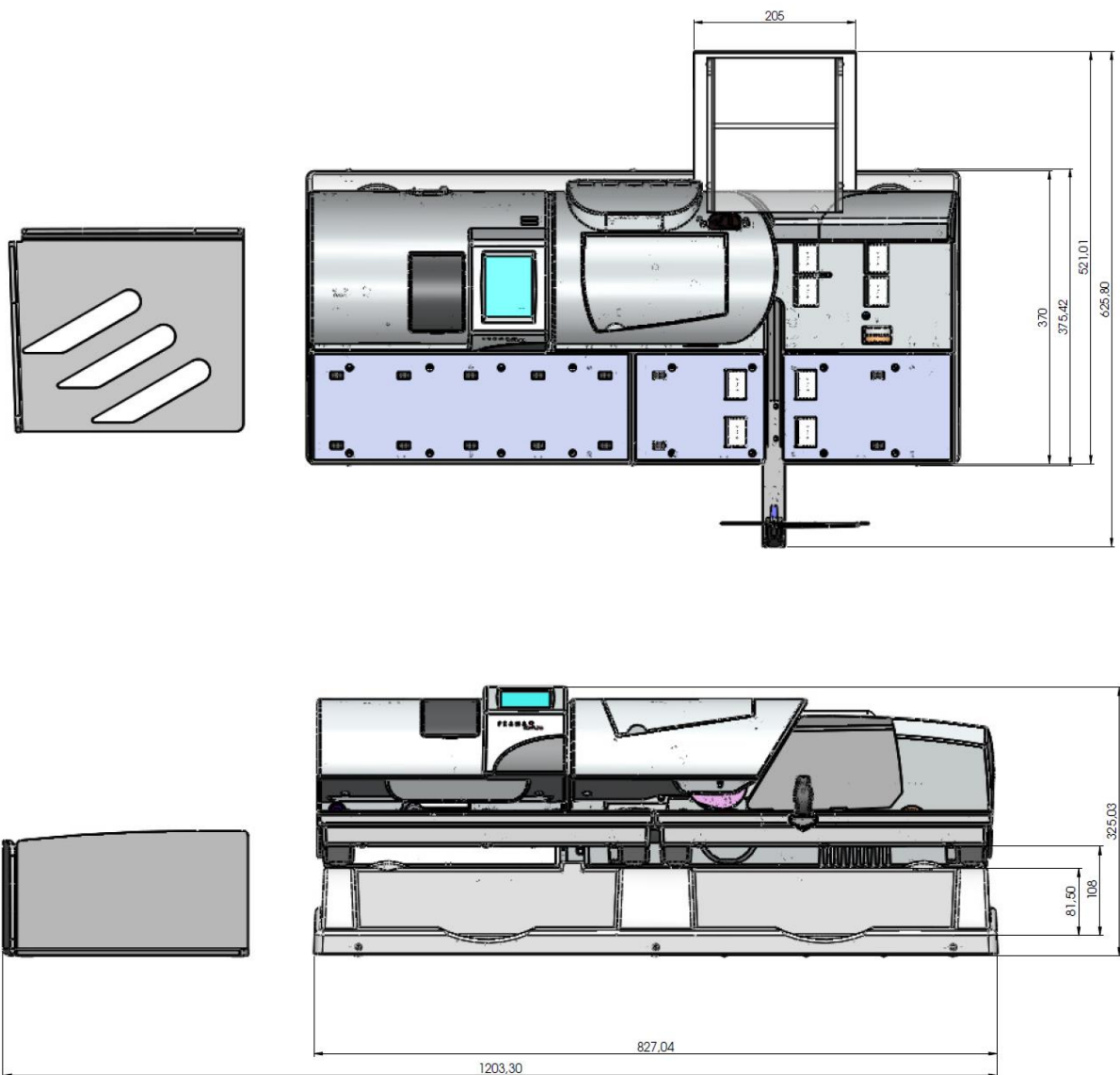

Weight: 18.4 kg

11.5. Accessories

Visit www.framashop.uk or speak to your local Frama Sales and Service organisation.

11.6. Storage and operating conditions

Matrix F82 operating conditions:

Temperature range: 10°C - 40°C

Relative air humidity: 10% - 80% (not condensing)

Approved for indoor use only up to a maximum of 4000 metres above sea level

Overvoltage category II

Pollution degree 2

Ink jet cassette operating conditions:

Temperature range: 10°C - 40°C

Relative air humidity: 10% - 80%

Ink jet cassette storage conditions:

Temperature range: 10°C - 30°C

Relative air humidity: 5% - 80%

12. EC-Declaration of Conformity

in accordance with the EEC low-voltage directive 2006/95/EG in accordance with appendix III B; of December 12, 2006

Hereby we explain that those corresponds to below designated products in its conception and design as well as in circulation the execution the fundamental safety and health requirements of the Community directive low-voltage brought by us. In the case of a change of the product not coordinated with us this explanation loses its validity.

Manufacturer:

Frama AG
Dorfstrasse 6
CH-3438 Lauperswil

Description of the electrical equipment:

Product name: Matrix F82
Type: Franking system

The agreement with further valid guidelines/regulations following for the product is explained:

EMC Directive (2004/108/EG) of December 15, 2004

Reference to the harmonised standards:

EN62368-1:2020

EN 55014-1:2006 + A1:2009 + A2:2011
EN 55014-2:1997 + A1:2001 + A2:2008
EN 55022:2010
EN 55024:2010
EN 61000-6-1:2007
EN 61000-6-3:2007 + A1:2011
EN 61000-3-2:2006 + A1:2009 + A2:2009
EN 61000-3-3:2008

Lauperswil, November 1, 2013



Thomas P. Haug
CEO

13. Index

A

Accessories	69
Admin mode	55
Advertising imprint	45
AF feeder	31
Auto Log off.....	53

B

Bring date forward	44
--------------------------	----

C

Calibrate	28
CC Manager	19, 54
CC report.....	45
Change PINs.....	56
Changing the ink jet cassette	49
Check sum.....	50
Cleaning letter sealer	33
Clearing paper jam	35
Colour Scheme.....	51
Communications module.....	13
Connecting feeder.....	36
Connecting the feeder and franking system	12
Connecting the franking system	36, 37
Connection	58
Connections	13
Controls.....	10
Cost centre data.....	19
Cost centre name	20
Cost centre period	18
Cost centre PIN	20
Cost centres.....	18
Count Only.....	34
Counter Readings	20, 50, 56
Credit:	50

D

Declaration of Conformity.....	71
Delete CC.....	53
Detail-guided.....	21, 22
Determining postage value.....	21
Determining the weight	23
Devices	43
Dimensions of advertising message	67
Disconnecting the franking system	36
Disposal.....	9

E

Entering an advertising imprint text block ..	40
Envelope formats	67
Error messages	61

F

Feeder	43, 55
Feeder menu	31
Fill with water	32
Fitting the ink jet cassette	27
FramaOnline2	15, 16, 53, 58, 61
FramaOnline2 report	45
Franking.....	25
Franking labels	26, 30

H

High Value	53
------------------	----

I

Info Print.....	45, 56
Inserter Mode.....	34, 54
Inspection	58
Inspection/AutoConnect	17
Installation	12
Installation notes	7
Installing the ink jet cassette.....	15

K

Key Beep	53
----------------	----

L

Label alignment.....	49
Label dispenser	26
Language	51
Last Report	59
Loading postage credit	16, 58
Log in	55
Logo.....	39, 54, 55
Low Credit	53

M

Main Menu.....	39, 55
Mains connection.....	14
Max. Value	53
Maximum letter thickness:	67
Message and text.....	41
Messages	39

N

Nozzle cleaning	47
Nozzle test	47
Numeric keypad.....	21, 23

O

OneTouch.....	21
Operating conditions.....	70
Order accessories.....	60

P	
PIN Code	53
Postage scales	23
Power supply	68
PP analogue	42
PPI	42
PPI report	46
Print alignment	49
Print date	44
Print head new calibration	49
Print Report	59
Printer Settings	47, 56
Printing out reports	45
R	
R1-Value/R1-Number	50
R2-Value/R2-Number	50
Receipt stamping machine	45
Received stamp	45
Recycling	9
Release button	37
Report system	45
Reset Counters	52, 57
Reset Product on Log Off	54
Restart System	18
S	
Safety instructions	7
Save Start Menu	52
Scales	43
Scales messages	62
Scales mode	43
Screen layout	11
Seal Only	34
Sealer	32
Sealing system	13
Select cost centre	19
Send order	60
Separating feeder	36
Service (Printer Settings)	49
Setup	51
Setup 1	56
Setup 1 menu	51
Setup 2 menu	53
Setup 3 menu	54
Side stop	25
SINGLE mode	24
Specimen	46
Speed:	67
Stack function	34
STACK mode (default)	24
Start menu	11
Start Up/Log Off	52
Statistics report	46
Status List	52
Storage and operating conditions	70
Switching on and off	18
Switching the message off	41
Symbols used	4
System Info	51
System screen	11
T	
Tariff-guided	21, 23
Technical data	67
Text blocks	40
Thorough cleaning of nozzles:	48
T-Number/T-Value	50
Touch screen	51
Troubleshooting	61
U	
Uninstall	58
W	
Weighing a stack of mail items	24



Sales and service centre:
Frama UK Limited, Hoddesdon

- Questions on the operation of the franking system
- For problems with the connection; online system

Help line: 01992 451125

Ordering consumables: www.framashop.co.uk or your local Frama Sales and Service organisation.

www.frama.co.uk