

Fn Series 7

Quick Installation Guide

Machine components:

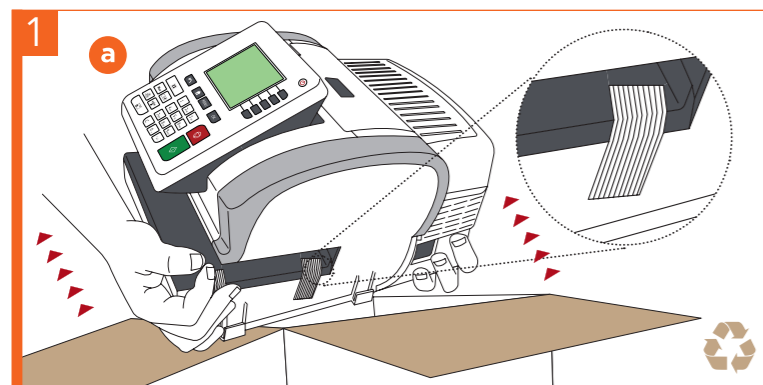
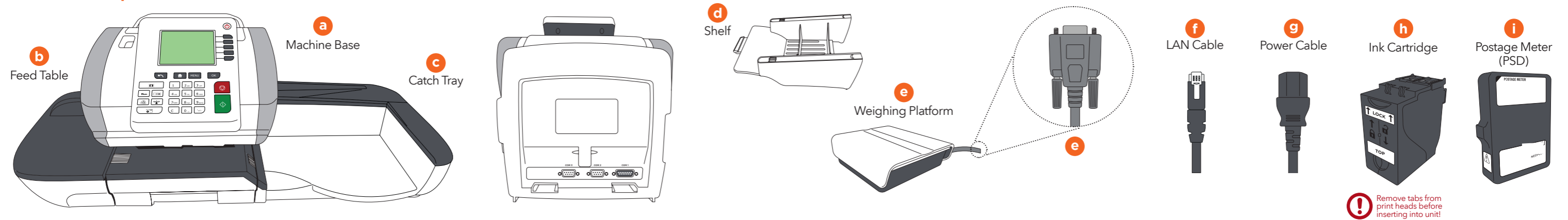

1. Unpack all components from the box, remove packaging and any transit tape.

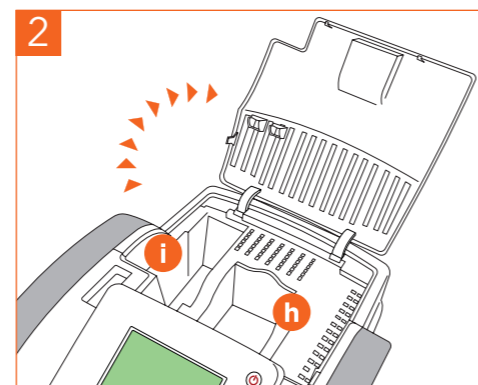

2. Lift the cover of the machine to reveal the Ink Cartridge (h) and Meter (i) locations.

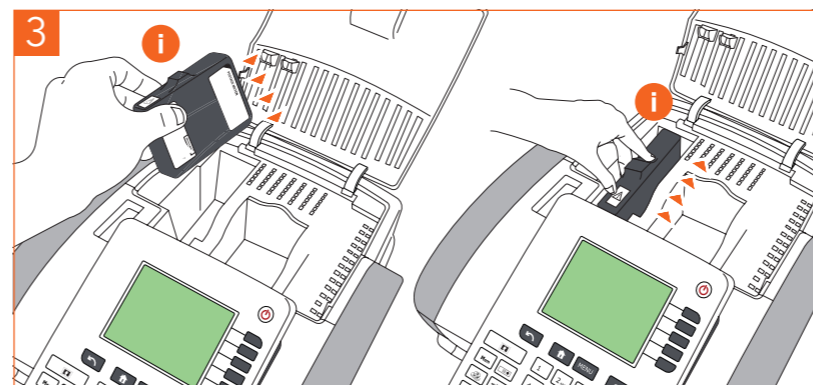

3. Place the Meter (i) into the meter compartment and push backwards until it slots into position.

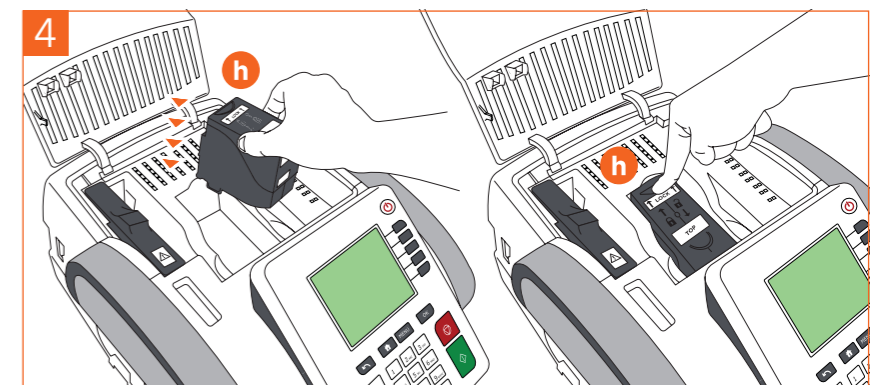

4. Insert the Ink Cartridge (h) at an angle into the machine with the 'TOP' and 'LOCK' stickers facing upwards. Push the Ink Cartridge (h) towards the back of the machine until you hear a 'click' - close the cover of the machine.



5. Lift machine slightly on the left hand side and align the hooks to attach the Feed Table (b) - attach the Catch Tray to the right hand side of the machine (c).



6. Attach the Weighing Platform (e) and Shelf (if applicable) (d).

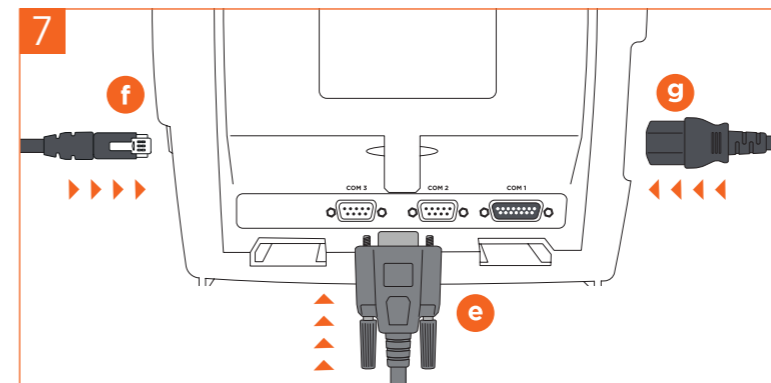

7. Connect the Weighing Platform (e) connector into a COM PORT on the rear of the machine. Then connect the LAN Cable (f) and Power Cable (g) to either side of the machine.

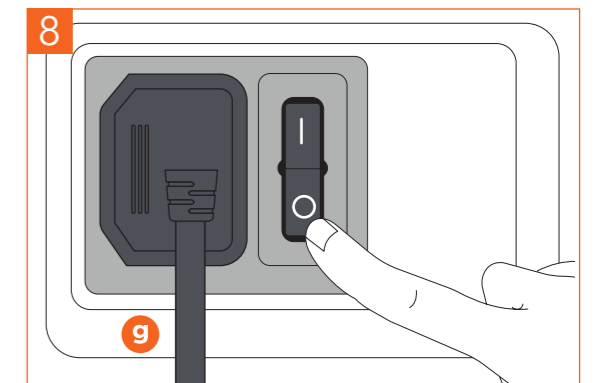

8. Turn on the machine using the switch behind the Power Cable (g) and follow the steps on screen.

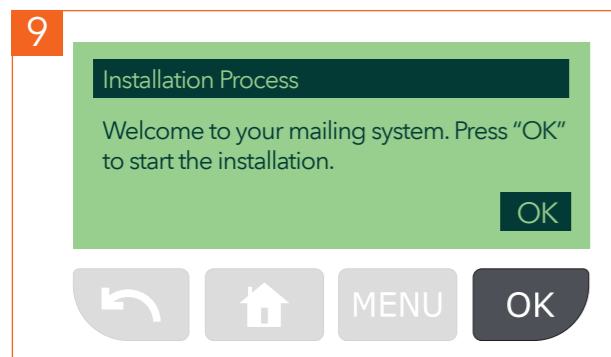

9. Press OK to start the installation.

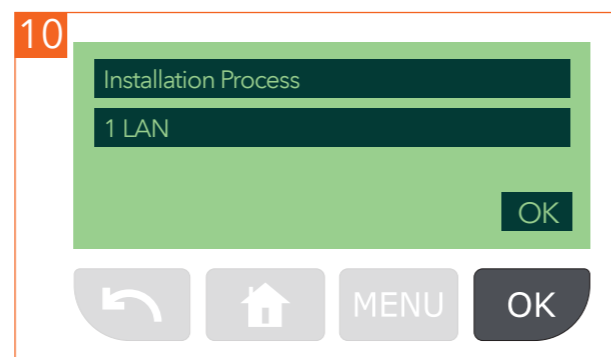

10. Follow the step by step instructions.

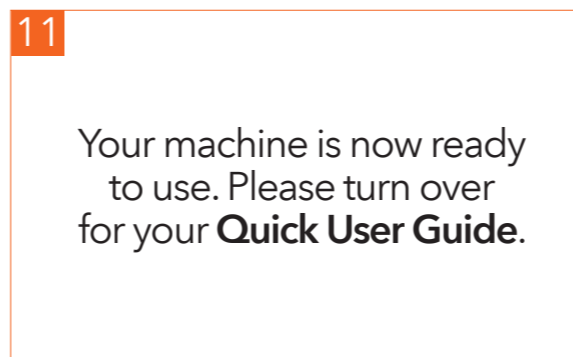

Your machine is now ready to use. Please turn over for your **Quick User Guide**.

Getting to know your Franking Machine

Screen Information

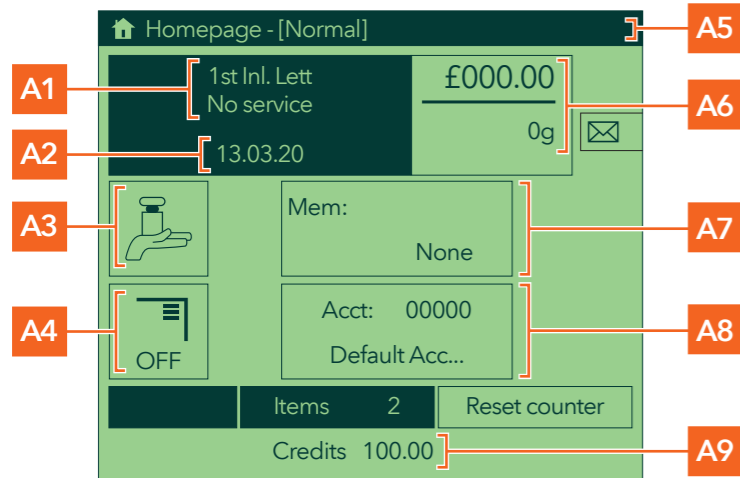

- A1 Rate and services (to change: B1)
- A2 Date printed (to change: B6)
- A3 Weighing type (to change: B5)
- A4 Imprint position offset
- A5 Type of imprint (to change: B4)
- A6 Postage and weight
- A7 Memorized job (can contain rate, stamp settings and account)
- A8 Current account
- A9 Credit (adding funds: B3)

Shortcut keys

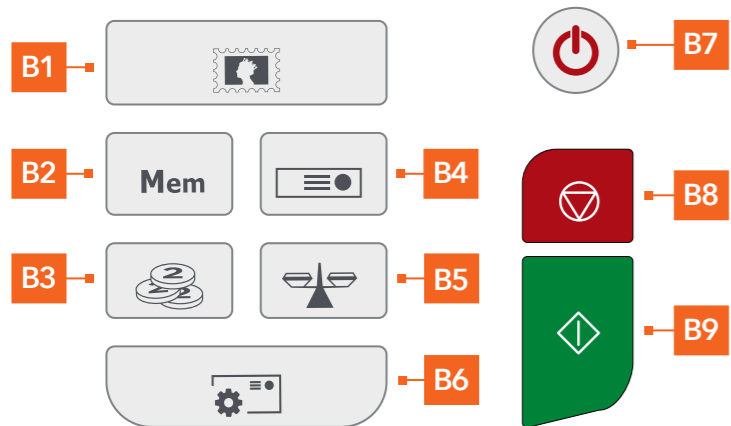

- B1 Rates and postal services selection
- B2 Memorized jobs (rate, stamp settings and account)
- B3 Credit management
- B4 Label printing
- B5 Weighing modes
- B6 Type of imprint and imprint settings
- B7 Sleep/wake (amber/green)
- B8 Stops printing
- B9 Starts printing

Quick steps to franking your mail

- 1 To reset the machine...
Press:
 - to clear the information on screen.
 - to wake the machine up with default settings.
 - to return to the home screen.

- 2a To weigh an item...
Put the mail on the platform:
 1. Check that the A3 icon is
 2. Otherwise press and select the option: **Standard weighing**

- 2b or, if you know the weight...
Key the weight in manually:
 1. Press and then select the option: **Manual weight entry**
 2. Enter the weight and press

- 3 When the weight is displayed...
Select a rate (and services):
Currently selected rate and services are indicated at the top of the screen.

Change/add services:

1. Press
2. The Rate selection screen is displayed.
3. Use the keypad to choose a rate or service option, or use the wizard for access to more rates.
3. When done, press to confirm your selection and return to the home screen.

- 4 When all steps are completed...
Print the stamp:
If you want to print on a label or automatically seal the envelope, check additional options below.
 1. Press to start the motors of your franking machine.
 2. When the rollers start, insert the mail into the machine from the left hand side.
- To print on labels:**
1. Insert labels into the dispenser until a click, printing side facing the right.
 2. Press to enter the number of labels to print and then press
- To seal the envelopes**
1. To seal the envelopes (if applicable) Use the button at the front of the feeder. Check water level in the bottle.

Adding credit

- Press choose 'Credit' and follow the instructions on screen.
- Note:** in order to add credit to the machine there must be funds available in your postage account. For more specific information on your franking machine, please visit www.frama.co.uk/Fn7

Changing the ink cartridge

1. On the new ink cartridge, remove the protective strips from the printing heads.
 2. Lift machine cover and follow instructions printed on sticker inside.
-

If Jamming occurs

1. Press on the key pad to stop the motor.
 2. Under the base, lift up the release handle and, using your other hand, remove stuck envelope.
-